

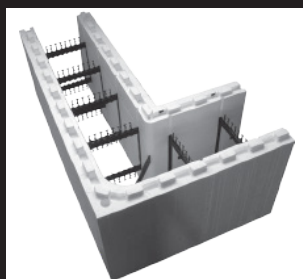

FLOWERS

ICF Blocks Insulated Concrete Form Technical Guidebook & Training Guide

Innovative Technology from a name you can trust



FLOWERS



Industrial Strength Insulated Concrete Forms (ICF)



CONTENTS OF GUIDEBOOK

Why Contractors are Choosing Fox Blocks

Fox Blocks Training Programs	3
Fox Blocks End View Sizing	4
Fox Blocks Line-Up	5
The True Cost of Fox Blocks	6
Remove Costs on Your ICF	7
Project Fox Blocks Interlock	8
Fox Blocks Studs	10

Fox Blocks Products & Accessories

Extended 90° Corner	11
Fox Blocks T-Block	12
Fox Blocks HV Clip	13
Fox Blocks Curb Block, Installation, & Uses Fox Buck Continuous Insulation & Installation Fox Blocks Energy Stick	14
xLerator Ledge Reinforcement	18
tieKey ICF Masonry Anchor	20
	21

How-To Section

Fox Blocks Steel Shelf Angle	22
Attachment Fox Blocks Rim Joist	23
Attachment	24
Field Cut Corners Fox Blocks	25
Shallow Frost/Stem Walls	26
ICF Bracing/Scaffolding	

Estimating Fox Blocks

Fox Blocks Estimator	27
PRO 4 Sample Cross	28
Sections Basic Estimating	30
Man Hour Rates	32

Appendix

Technical Performance Data Fox Blocks By The Numbers	33
	34

FOX BLOCKS TRAINING PROGRAMS

As Fox Blocks expands throughout North America, training courses follow to ensure proper knowledge and techniques are used during installations.

Trainings are tailored to the region and focus on contractors, building officials, Engineers/Architects, and building supply yards.

When installing contractors complete a training, they are required to complete the proper paperwork to earn a wallet card (see at right). This wallet card can be used when asked for by building officials.

As contractors gain experience, Fox Blocks rewards them with higher level wallet cards. This allows us to understand how qualified the contractor is for larger, more complicated Fox Blocks jobs that are looking for installers.

TRAINING OBJECTIVES

- 1) Understanding ICF
- 2) Estimating your job
- 3) Crew Sizing for your job
- 4) Basic Installation of the Fox Block Line-Up

INSTALLER LEVELS

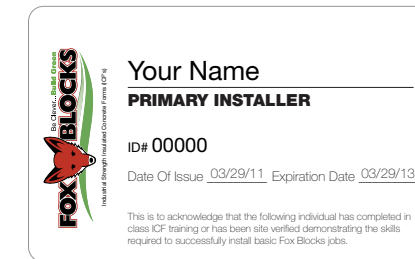

PRIMARY INSTALLER: Successfully completed one ICF project or completed in class training.



JOURNEYMAN INSTALLER: Successfully completed 5 Fox Blocks projects (or 1500+ Block).



MASTER INSTALLER: Successfully completed 15 Fox Blocks projects (or 4500+ Block).
Regional Manager & Dealer will Confirm

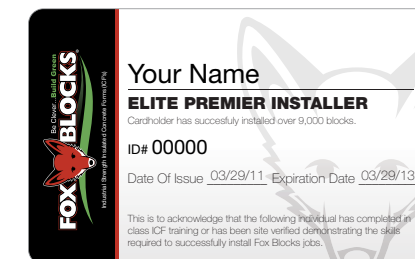

ELITE PREMIER INSTALLER: Successfully completed 30 Fox Blocks projects (or 9000+ Block).
Regional Manager & Dealer will Confirm



Why Contractors are Choosing Fox Blocks

FOX BLOCKS END VIEW SIZING

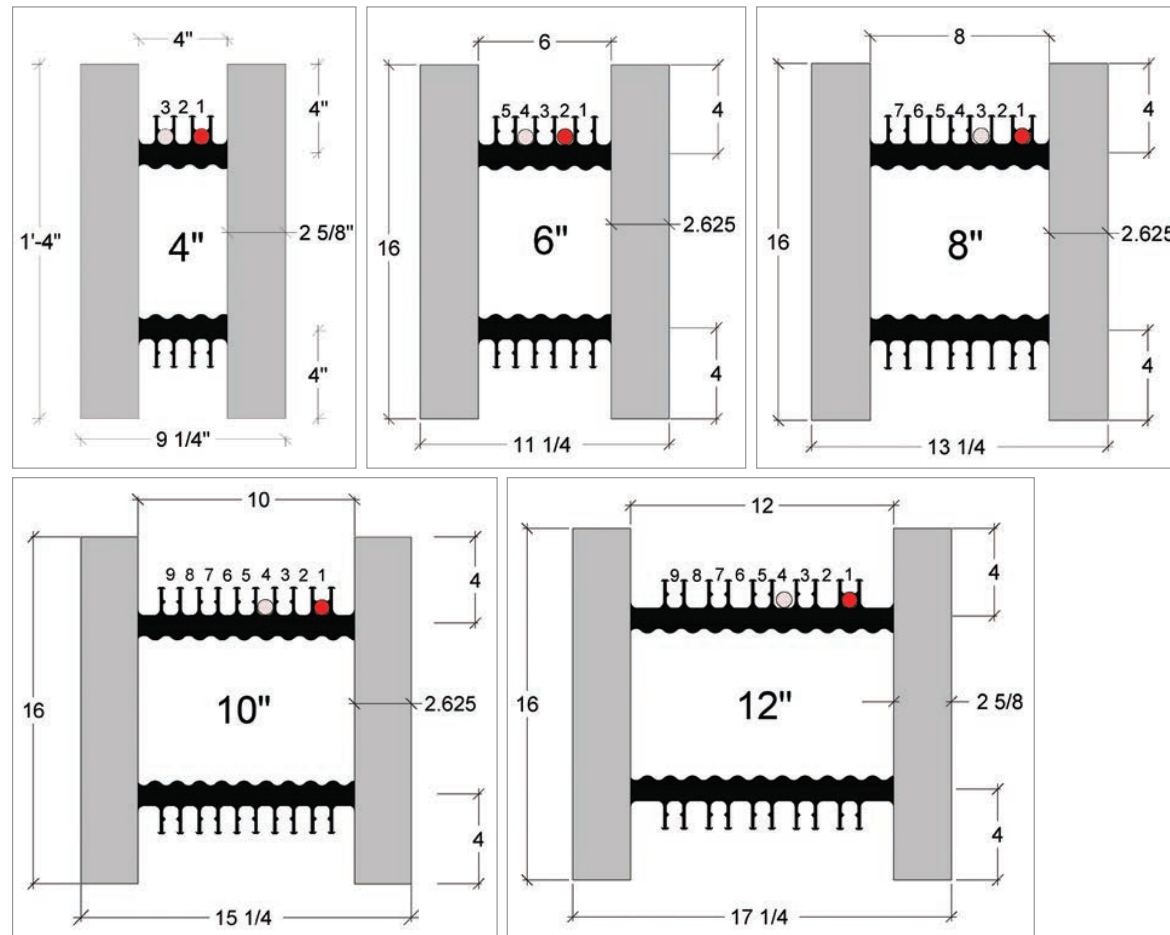

NOTES:

- 1) Straight Blocks are 48" in length.
- 2) All block have 2 5/8" EPS for consistent R-Value.
- 3) Rebar spacing is consistently 16" o/c and lower truss is 8" o/c from top or bottom of upper truss.
- 4) All block work with each other, example the 4" block will connect to all sizes of block.
- 5) The 4" block is the size of a 2 x 10 and the 6" block is the size of a 2 x 12 which is perfect for wood bucks.
- 6) Rebar notches are designed to lap rebar on top of each other to ensure proper concrete placement.

FOX BLOCKS LINE-UP

With advice from leading contractors in the Insulated Concrete Form business, Fox Blocks has created an incredible group of blocks.

FOX BLOCKS LINE-UP INCLUDES:

(Please note: Fox Blocks are reversible. As an example, each corner block is a left or a right.)

- A) STRAIGHT BLOCKS**
Available in 4", 6", 8", 10" and 12".
- B) STRAIGHT 1/2 BLOCK**
Available in 4", 6", 8", 10" and 12".
- C) EXTENDED 90° CORNERS**
Available in 4", 6", 8", 10" and 12".
- D) EXTENDED 90° CORNER 1/2 BLOCK**
Available in 4", 6", 8", 10" and 12".
- E) 45° CORNER BLOCKS**
Available for 4", 6" and 8".
- F) T-BLOCKS**
Available in 6" and 8".
- G) CORBEL LEDGE BLOCKS**
Available in 6" and 8".
- H) RADIUS BLOCKS**
For 5', 6', 7', 8', 9' and 10' radius.
Only available in the 6" blocks.
- I) TAPER TOP BLOCK**
Available in 6" and 8".
- J) CURB BLOCK**
Available in 8" Straight and 90°
- K) 4" HIGH EXTENSION**
When you need extra height or to help with openings.
- L) ENERGY STICKS**
One size fits all.
- M) FOX BUCK**
Available in 4", 6", 8", 10" and 12".

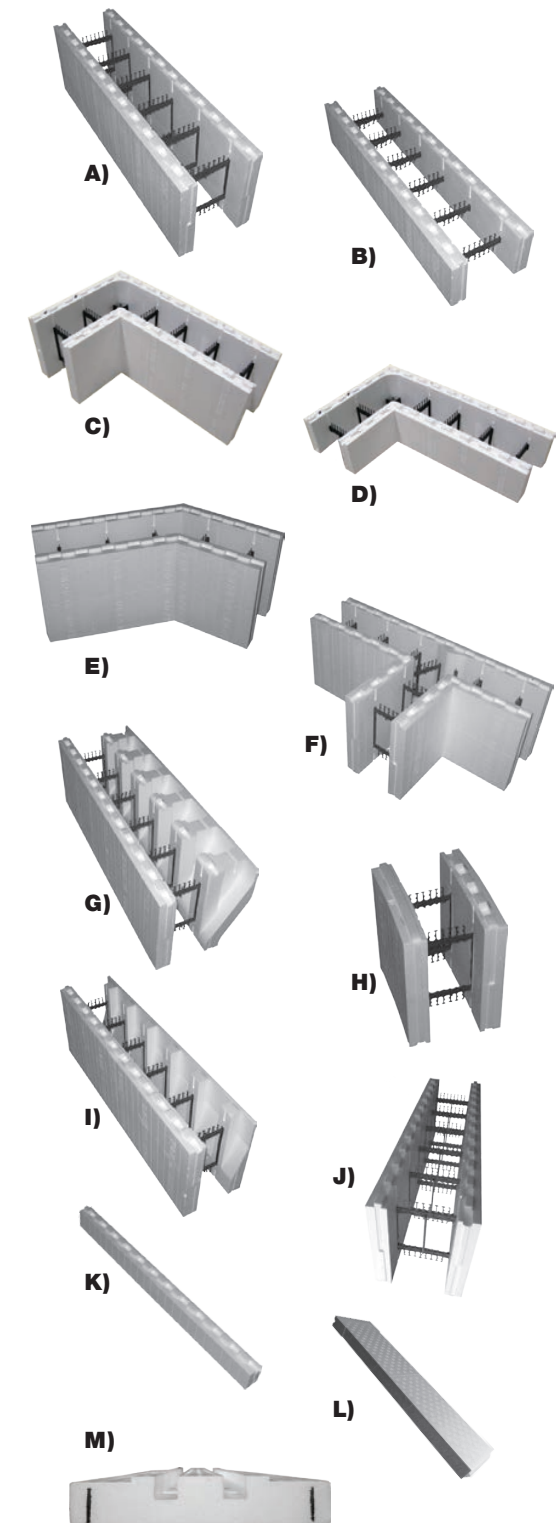



Why Contractors are Choosing Fox Blocks

THE TRUE COST OF FOX BLOCKS

To help understand the cost advantage of using Fox Blocks Industrial Strength Insulated Concrete Forms (ICF) consider the following key points:

THREE KEY AREAS GIVE YOU THE TRUE ACCURATE COST OF THE ICF YOU CHOOSE:

1) ICF BLOCK COST

Most ICF fall to within \$0.10 per square foot of each other in block cost which is a minor portion of the overall cost of the wall construction. You must get "All-In" landed ICF System cost to accurately compare.

2) ANCILLARY PRODUCT COST

Add in all ancillary product costs that are not in the block quote. A common example is most ICF require internal truss wire to give needed strength to the system. Know what's required within system install guidelines to produce a straight wall. See other side for examples that will save you time & money on your next job.

3) MAN HOUR RATE TO INSTALL

Eliminating tasks will shave hours/days off the project. Installation labor is the largest portion of overall ICF cost. Seek full disclosure on man hour rates to install the ICF system you are considering. Listening to experienced installing contractors and gaining an understanding of the attributes of ICF products can make the difference between a streamlined, profitable job and one that is not.



AT FOX BLOCKS:

EXPERIENCE

Airlite Plastics Co., the parent company of Fox Blocks, manufactured many different brands of ICF over the past 15+ years. Much experience was gained while producing over 56 million square feet of ICF. Designed, engineered and delivered to your local market.

COMPETENCE

Airlite Plastics controls all aspects of development and production = "Industry Leading Products".

COMMON SENSE

We went to the field and asked the professionals what they needed to be effective and efficient. After listening to them we produced an Industrial Strength ICF called Fox Block!

STABILITY

Since 1946 the family run Airlite Plastics business has grown and provided high quality proven products over the decades. We have and will continue to provide the highest quality products to the construction industry for years to come.

REMOVE COSTS ON YOUR ICF PROJECT

TWO PROVEN AREAS TO REMOVE COST:

1) CORNERS

PROBLEM: Historically, Corner Blocks have proved to be very difficult for installing contractors to hold the corner positioning or actually holding concrete during the consolidation process. Contractors have resorted to inserting internal ties, external strapping and bracing to gain needed strength. This adds cost in additional materials and man-hour rates.



Some competitive ICF strap corners with lumber for strength during concrete placement.

SOLUTION: Our engineering staff at Fox Blocks developed more length to the corners and introduced the heaviest cross tie corner bracket on the market. Adding these features to our large/strong interlock stopped rotation and movement within the blocks during the pour and added needed burst strength. Having this bracket, and no less than two ties from each corner in all 45° and 90° block, eliminates need for additional strapping or internal ties.

RESULT: Confidence to the installing contractor, lower man hour rates, and lower material costs proven by over 9 years of successful projects. Utilizing our Fox Blocks "next generation" corner block design will save you money through time and material reductions.

COST: The Fox Blocks corners cost the same per square foot as the Fox Blocks straight block. Cost may appear higher than our competitors because our corners are 16" or more in length. In many cases, our corners are actually lower in cost per square foot and at the same time save you even more in time and materials.



The Fox Blocks extended 90° corner block showing it's stand alone strength during concrete placement.



The Fox Blocks extended 90° corner block with an extra tie on each end for strength.

2) TRUSS WIRE (FORM LOCK, BLOCK LOCK)

PROBLEM: Some ICF interlocks and slender plastic webs have caused the need of internal truss wire to aid in producing adequate strength to add rigidity to produce a straight wall.

SOLUTION: Two very simple Fox Blocks innovations cured this problem: 1) A bold and reversible interlock was created to help hold the wall true. 2) A full height internal tie was designed to use solid stacking strength to hold the wall from settling or racking.

RESULT: A wall that, through design, eliminates the need for truss wire.

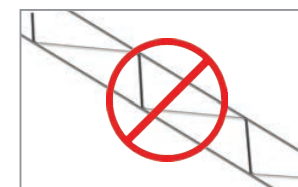

USING FOX BLOCKS ELIMINATES THE NEED FOR TRUSS WIRE

Truss wire costs over \$0.50 per lineal foot and is called for at bottom of wall and then every 4 or 5 rows of block. Actual cost = Over \$0.14 per sq ft in materials and at least \$0.04 per sq ft labor for a total of \$0.18 or more per sq ft cost. This is equivalent to \$0.40 per block



Why Contractors are Choosing Fox Blocks

FOX BLOCKS INTERLOCK

THE OLD

For the past 20+ years the interlock of most ICF in the industry have been designed to be within 1/2" to 1" of the desired building dimension. Most contractors have been trained that it is acceptable to be this far off the desired dimension.



Shows the large 2" long projections and recesses and the full height 1 1/2" wide tie

THE NEW

When the Fox Blocks interlock was designed, our engineering staff made the choice not to focus on being within 1/2" to 1" from the building dimension but to give the strongest interlock possible. To do this they turned the projections and recesses of the interlock parallel to the block itself and for simplicity/strength they made them 1" wide and 2" long.

Walls should be square and built to the building dimensions. For this reason Fox Blocks recommends stacking seams when needed.



Here is a job, post concrete, that has been constructed exactly to the building dimension by properly stacking seams.

BENEFITS OF THE LARGE INTERLOCK:

- Minimized movement during concrete placement
- No adhesive required due to tightness of interlock
- Eliminates the need for truss wire within the wall
- The full height ties are always on top or 4" apart of each other

Review next page to see the proper procedure for stacking seams.

THE NEW TRAINING:

ROW ONE:

Simply start from each corner to a point within the wall. Cut one of the blocks to fit perfectly. The cut does NOT need to be on the cut lines. Measure the cut block and mark its measurement to the side of that block large enough for everyone to see.

ROW TWO:

Start at the corners again placing the corner block the opposite direction from row one to give an overlap with the block. When you reach the cut block on row one, cut the block above it to line up exactly. Again the cut does not need to be on the cut line. Measure the cut block and mark its measurement to the side of that block large enough for everyone to see.

ROW THREE:

(five, seven, nine, etc)
Should be exactly the same as row one.

ROW FOUR:

(six, eight, ten, etc)
Should be exactly the same as row two.

PRIOR TO CONCRETE:

Simply connect the vertical seam that you created, at the one point in the wall, with strapping, or plywood, on both sides of each block. Use one 12" to 24" long strap, 3" to 6" wide, made out of 1 x wood boards or plywood sheathing attached with one screw in each tie on each side of seam.

RESULTS:

We have found that the man hour rate will drop using this method because the crew spends less time thinking how they can get closer to the building dimension and more time actually being productive.



WRONG



CORRECT

We have found it to be a waste of time and energy to attempt to offset or stagger the block, at the meeting point, as in the photo above-left. By creating a vertical stacked seam, you will be more accurate with the job dimensions and will increase your profit by gaining efficiency with your crew.

BUILDING MULTIPLE LEVELS WITH DIFFERENT SIZED BLOCK

All sizes of Fox Blocks ICF fit well on top of each other for any type of configuration with little or no modifications needed. This is simple math. Fox Blocks are reversible with 2" projections and recesses which means you will work with a 4" offset. For this reason the 4", 8" and 12" block all work well together as they are all divisible by 4". Using the same math, the 6" block attaches to all sizes of Fox Blocks with a 2" difference in tie alignment. This is not a concern as this joint line will usually happen at a floor diaphragm.

6" CORNER BLOCK ON TOP OF 8", 10" OR 12" CORNER BLOCK:

The 6" corner works well on top of the 8", 10" or 12" corner blocks when going around an outside corner. For inside corners, simply remove the projections off the corner block and continue building. You may need to create a stacked seam on one or both sides of the inside corner at which time we recommend you just move the stacked seams for each wall closer to that inside corner.

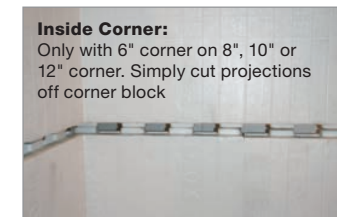

6" 90° corner block on top of 8", 10" or 12" 90° corner block

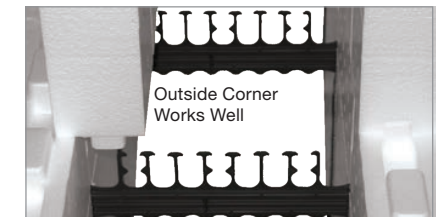



Why Contractors are Choosing Fox Blocks

FOX BLOCKS STUDS

You are a sheetrock, residential wood frame, commercial steel stud or siding contractor that has been trained, and are efficient with, a continuous 1 1/2" wide attachment surface @ 16" on center.

Our team at Fox Blocks agrees with this tradition and have created our ICF with the same continuous 1 1/2" wide attachment surface but increased it to 8" on center.

Just think, when attaching sheet rock or siding to Fox Blocks Insulated Concrete Forms, you can use the same training you have used until now and understand.



FOX BLOCKS ICF

- A full 1 1/2" wide
- 8" o/c to achieve industry standard 16" o/c's
- No gap every 16" vertically due to ties touching
- Minimal settling due to ties touching
- Not effected by moisture, will not rot
- Will not move due to temperature and humidity changes
- Eliminates most sheetrock / drywall repairs
- Made of non-organic materials



ACTUAL FOX BLOCKS WALL

- Studs clearly marked @ 8" o/c
- Studs are in contact with each other vertically
- Studs buried into foam 5/8" for stucco application and thermal performance

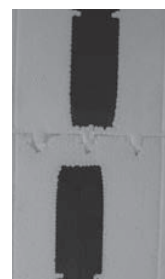

OTHER ICF

- As narrow as 1" wide
- As much as 1 3/4" gap every 16" vertically due to ties not touching
- Settling due to ties not touching



WOOD STUDS TODAY

- Much larger grain than 15 years ago
- More knots and checks than 15 years ago
- Reject screws more than 15 years ago
- Prone to movement through seasons
- Prone to rot when sealed with moisture
- Prone to sheetrock / drywall repairs
- Food for insects

FOX BLOCKS STUDS

- Recycled polypropylene
- LEED credits*
- 120 lbs+ pullout / shear strength with screws**
- Use screws that are the thickness of material plus 1 1/8" + in length.
- If the screws that you are using do not hold, try the next size longer. The tip of the screw must pass completely through the tie to achieve full strength.

* See LEED documents at: <http://www.foxblocks.com/Resource-Center/Technical-Resources/LEED-and-Environmental-Documents.aspx>

** See testing results at: <http://www.foxblocks.com/Resource-Center/Technical-Resources/Testing-Reports.aspx>



Fox Blocks Products & Accessories

EXTENDED 90° CORNER

Fox Blocks engineered the 90 degree corner to hold concrete without the need for extra strapping or external bracing.

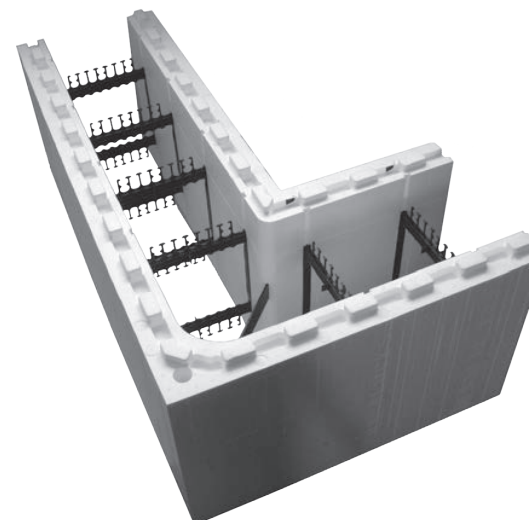

OTHER ICF 90s

- 5 to 5.33 total square feet of coverage
- More costly per square foot of coverage
- 16" shorter than Fox Blocks
- Only 4 ties
- Only one tie on short end
- More movement during concrete

FOX BLOCKS 90s

- 7.56 total square feet of coverage
- Less costly per square foot of coverage
- 16" longer than other ICF
- 6 ties
- Two ties on short end
- Less movement during concrete

Being 16" longer than other ICF allows you to eliminate one full straight block for every three Fox Blocks corners used. This also saves you money!

Radius on the inside face of the Fox Blocks Corners are:
4", 6" and 8" Blocks = 3" 10" and 12" Blocks = 8 1/2"
Additional EPS was added to the 10" and 12" Corner Blocks to give additional strength for the longer distance from corner to 1st tie.

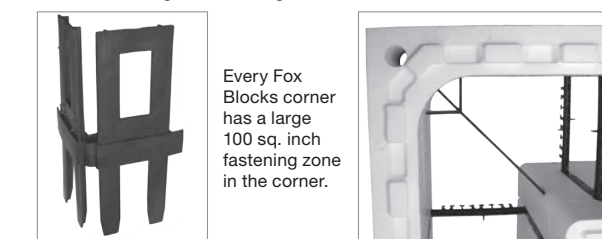

FOX BLOCKS EXTENDED CORNER FEATURES:

- 1) All blocks have Ties* at 8" o/c and are available in 4", 6", 8", 10" and 12" cavities.
- 2) Like all Fox Blocks, corner blocks are reversible so when you ask for a corner you will get the correct one every time. Each corner is left or right automatically!
- 3) Foam thickness is 2.625" on all forms.
- 4) Tie allows rebar lap splices to lay on top of each other for good flowability during concrete placement.
- 5) Ties are clearly marked on EPS for attachments.
- 6) Tie flanges are 1.5" wide and full height for ease of attachment.
- 7) Ties touch vertically when stacked, eliminating form settlement.
- 8) Each corner has a 1" hole strategically placed allowing the ICF contractor the option of inserting a full height 3/4" PVC conduit to tie all courses together for extra form support.

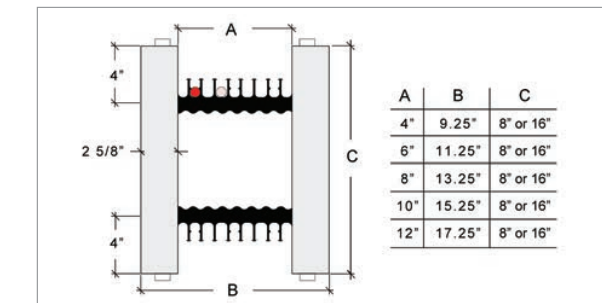

Fox Blocks 90° Extended Corner Size Chart

OUTSIDE DIMENSIONS ARE:

- 4" Corner = 38" x 22"
- 6" Corner = 40" x 24"
- 8" Corner = 42" x 26"
- 10" Corner = 42" x 26"
- 12" Corner = 46" x 30"



Fox Blocks Products & Accessories

FOX BLOCKS T-BLOCK

Sure you can build T walls with a couple of straight block and some tie wire but if you want to lower your Man Hour Rate you need the **Fox Blocks T-Block**.

When contractors said they needed a T-Block Fox Blocks delivered with one that is easy to use and incredibly strong.

FOX BLOCK T-BLOCK FEATURES:

- 1) The T-Blocks are available in 6" and 8" concrete cores.
- 2) Six T-Blocks per bundle (3 short and 3 long)
- 3) Two ties* are used at the intersection of the "T" to give maximum strength and attachment. These ties are placed in such a way as to allow proper rebar placement and ultimate form strength.
** Ties are the black recycled polypropylene members that give the block strength and provide rebar positioning.*
- 4) Like all Fox Blocks, blocks are reversible which gives you double the options with just one block. You can choose to have the T section on the right or left of center simply by flipping the block over.
- 5) Foam thickness is 2.625" on all blocks.
- 6) Ties allow proper rebar lap splices, for maximum flowability during concrete placement and consolidation.
- 7) Ties are clearly marked in EPS for attachments.
- 8) Tie flanges are 1.5" wide and full height for ease of attachment.
- 9) Ties touch vertically when stacked eliminating form settlement.
- 10) The T-Block will give you 8" of overlap most directions.

8" T-BLOCK INSTALLATION

The unique manufacturing challenges were overcome for the 8" T-Block by establishing a 4" offset. This off-set results in rows of ties staggered by 4" if placed with factory ends against each other. The easy fix to properly line up ties is to install the T-Block and create a stacked joint at the butt end of the long T leg. Strap stack joint prior to concrete placement.

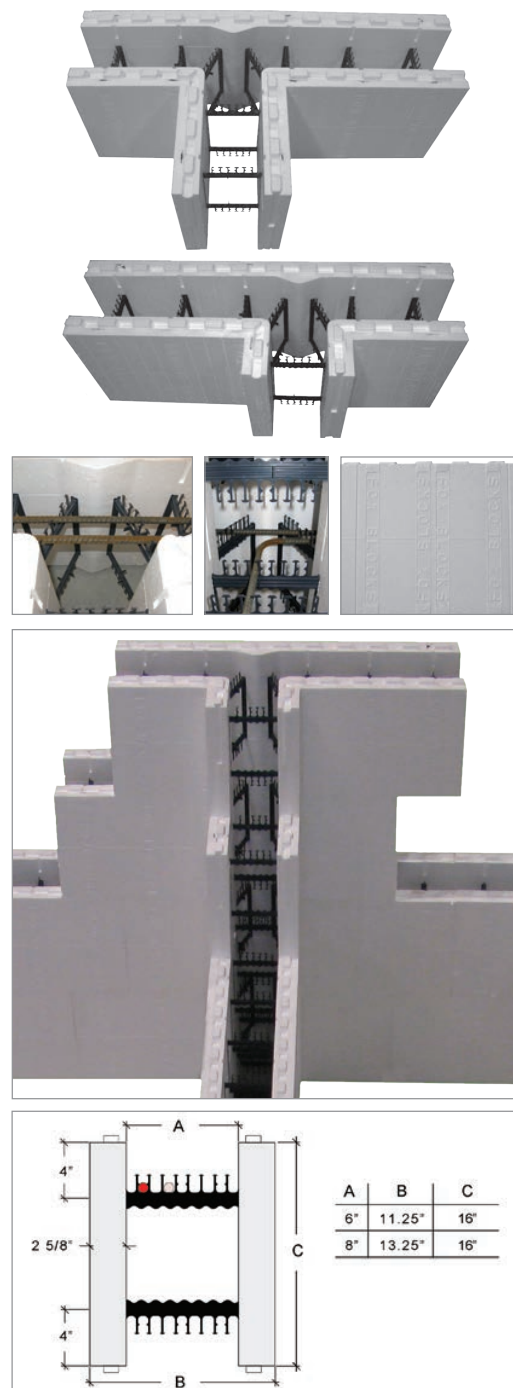

OUTSIDE DIMENSIONS ARE:

- 6" T - Block Short = 44" x 4.375"
- 6" T - Block Long = 44" x 12.375"
- 8" T - Block Short = 44" x 4.75"
- 8" T - Block Long = 44" x 8.75"

FOX BLOCKS HV CLIP

Contractors asked for a wire clip to secure their Fox Blocks jobs together so the team at Fox Blocks went to work designing one. Fox Blocks ties are engineered to be perfectly balanced, spaced at 8" o/c Horizontally and Vertically, giving flat walls post concrete. This allowed us to put all of our design into one wire clip which helps everyone with only one sku.

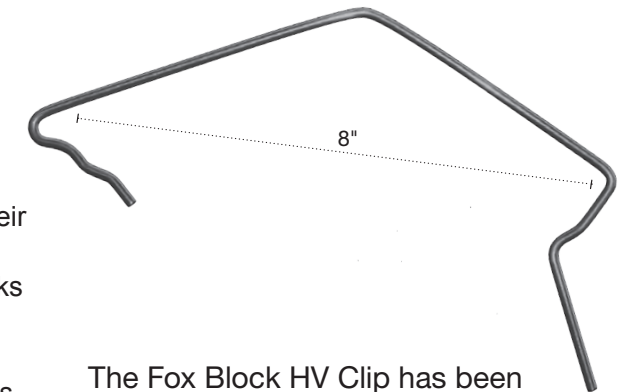

The Fox Block HV Clip has been engineered with eight bends allowing one clip to work horizontally or vertically.

HV CLIP PLACEMENT:

BOTTOM ROW:

Horizontally across every joint **1**

CORNERS:

Horizontally across each joint **1**

Vertically on first ties **2**

TOP ROW:

Horizontally across every joint **1**

Vertically on second tie from every joint **3**

OPENINGS:

Vertically up wall on each side of openings

BUDGET:

One box for every 150 block ordered

One box = 250 Fox Block HV Clips

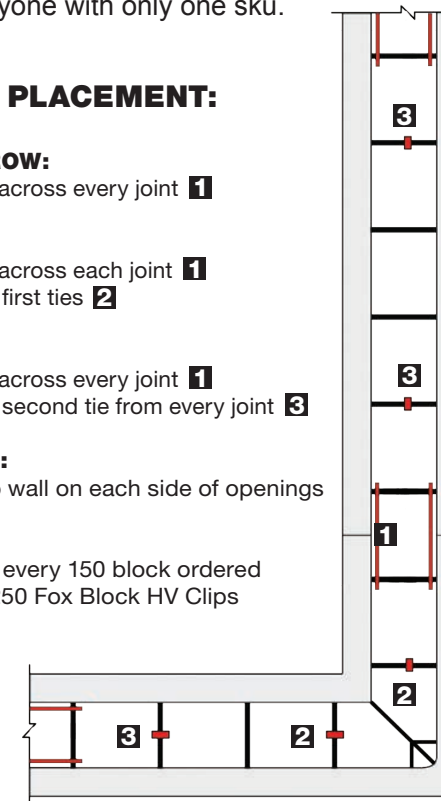

FOX BLOCK HV CLIP POSITIONS



Vertical Clips in Place Horizontal Clips in Place
Note: You can skew the HV Clip a notch or two for an even tighter fit, if needed.

FOX BLOCK HV CLIP BEING USED ON JOBS

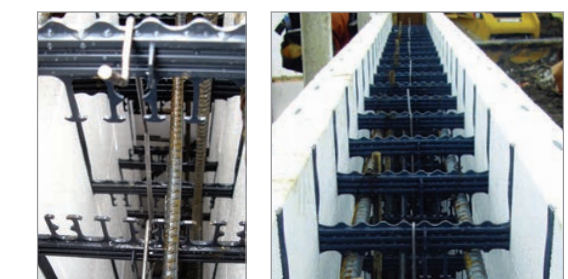

Vertical & Horizontal Clips in place close to corner Showing HV Clips holding down a top row that has been cut down to +/- 8" in height

Using the Fox Block HV clip eliminates the need for truss wire completely on your jobs. The result is that for about 1/2 the cost of the truss wire you will get a stronger and straighter job.



Product Label





FOX BLOCKS CURB BLOCK

There has always been a need for a block that can create a ledge to support floor systems within the wall without limiting course heights. The Fox Blocks team has solved this by adding an extra attachment point within the tie. This patent pending solution allows you to form a curb with the block to support whatever you need to support.

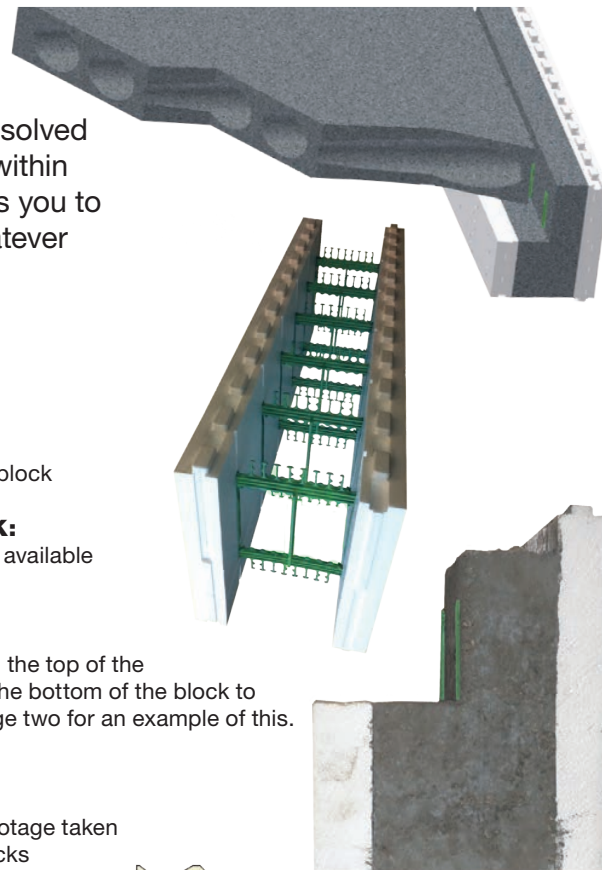

USING THE CURB BLOCK:

1) INSTALLATION

See following page for proper steps using the curb block

2) SHAPES AVAILABLE WITH THE CURB BLOCK:

At this time 8" Straight and 8" 90° corner blocks are available with the curb block

3) RANGE OF USE:

The Curb Block can be cut down as low as 11" from the top of the block. You can also cut up to as much as 11" from the bottom of the block to use when wrapping around concrete slabs. See page two for an example of this.

4) ESTIMATING:

Straight blocks = 4'-0" long.
 Formula: (Total linear footage of wall - total linear footage taken up by 90° corners) / 4 = Number of straight curb blocks
 90° corner blocks = 5'-4" each.
 Formula: Number of 90° turns = Number of 90° corner blocks

5) IDENTIFICATION:

The Curb Block has been designed with a green tie for easy identification. By producing the ties in green, supply yards will be able to identify and send you the proper block. This will also ensure your crew will not use it in the wall at the wrong time.

6) BUNDLE SIZES:

Straight block = 12 per bundle
 90° corner block = 6 per bundle

7) EXCESS BLOCK?:

If you end up with extra Curb Block on site, you can save for next job or simply use them up within the walls you are building. The shape and size of the Curb Block is identical to the normal straight and 90° corner blocks.

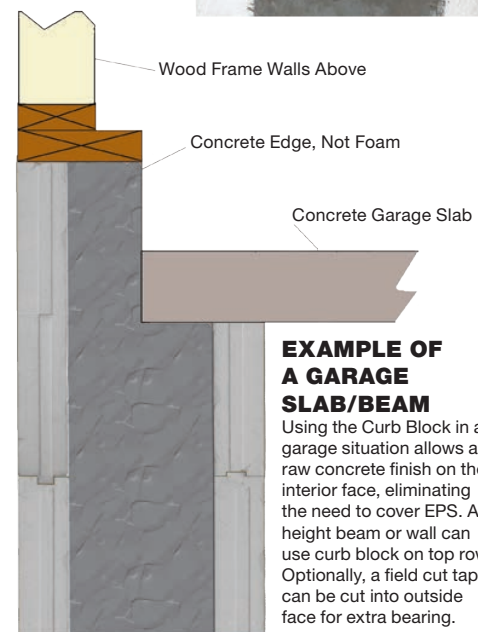

EXAMPLE OF A GARAGE SLAB/BEAM

Using the Curb Block in a garage situation allows a raw concrete finish on the interior face, eliminating the need to cover EPS. Any height beam or wall can use curb block on top row. Optionally, a field cut taper can be cut into outside face for extra bearing.



FOX BLOCKS CURB BLOCK INSTALLATION & USES

INSTALLATION STEPS:

STEP 1

Separate Curb Block bundles and set aside until needed. You can identify the Curb Block by the green ties.

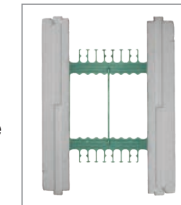

STEP 2

Decide where you need the concrete shelf elevation to land and either mark and rip-cut the block with a circular saw or set a fence on a table saw and make your cut. Finish cut by cutting the tie with a handsaw.

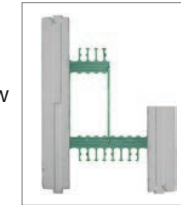

STEP 3

Attach forming to the Curb Block inner ties. Simply screw two #8 coarse threaded screws to each tie to withstand concrete pressure. Fox Blocks recommends the use of 1/2" or thicker plywood or equivalent.

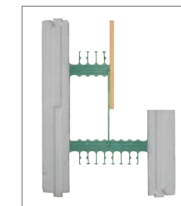

STEP 4

Place concrete as normal. For best results Fox Blocks recommends properly consolidating entire wall including Curb Block.

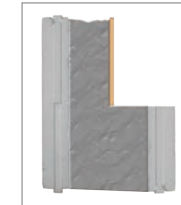

STEP 5

After sufficient curing remove form boards. You now have a solid concrete ledge for supporting what you need supported.

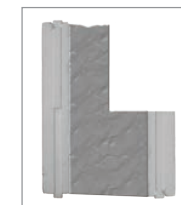

STEP 7

If you need extra support a taper can be cut prior to concrete placement to allow for up to a 6 1/4" ledge.

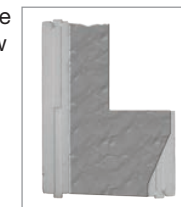

CURB BLOCK USES:

- Hollowcore
- Precast
- Dimensional Wood Floors
- Engineered Wood Floors
- Truss Floors
- Brick
- Garage Slabs
- Creating Recesses (See Below)
- Hambro Floors
- Pan Deck

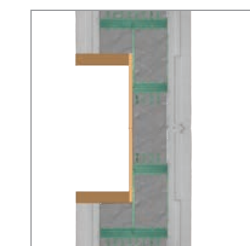

EXAMPLE OF A WALL RECESS

This type of application will be treated as an opening in the wall and will require extra reinforcing within the concrete (rebar). The Curb Block will allow openings up to 22" in height using two blocks.



WOOD FLOORS

For the real life example above we cut off 6" from the left side, turned the cut-off over and connected to the right side creating a 12" curb. This works well with wood floors giving you ultra strength without any concerns of moisture in the future.



Fox Blocks Products & Accessories

FOX BUCK CONTINUOUS INSULATION

The Fox Buck is a certified, fully integrated, continuous insulation window and door buck for commercial and residential ICF wall openings. Fox Buck completed 3rd party testing and obtained State of Florida product approval (FL 17775) for all of Florida, including Miami-Dade counties. To obtain certification and Florida code approval, the Fox Buck met and passed several tests related to wind and impact resistance, moisture and air infiltration, and fire related tests. The Fox Buck can be used in place of pressure treated wood bucks that tend to expand, contract, warp and move within the high moisture climates.



Dual full length 1" x 1" grooves to create solid concrete barriers against drafts and moisture penetration

Notches ensure proper Fox Buck and Fox Block alignment

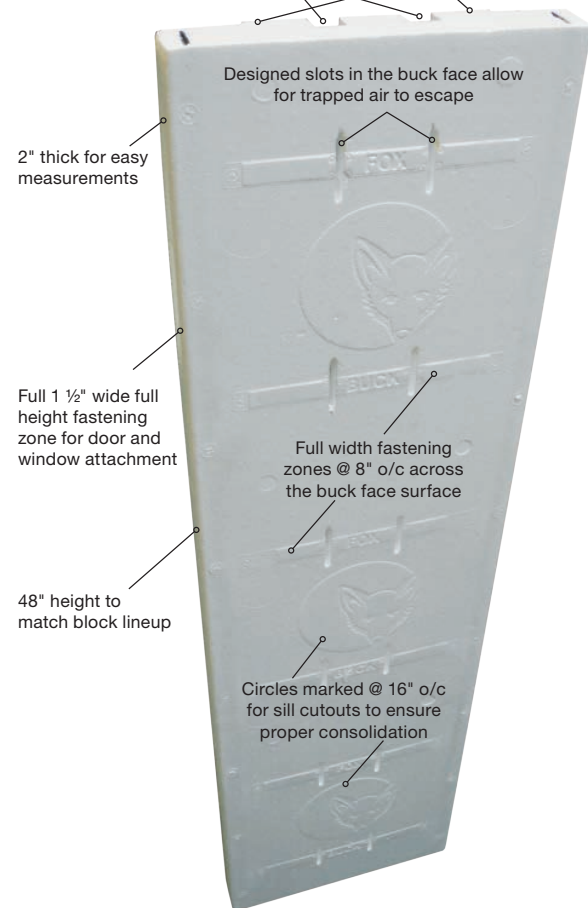

FOX BUCK NUMBERS					
Available Sizes	4"	6"	8"	10"	12"
Total Width	9.25"	11.25"	13.25"	15.25"	17.25"
Total Length	48"	48"	48"	48"	48"
Bundle Quantity	12	12	12	12	12
Bundle Weight	29 lbs	33 lbs	38 lbs	42 lbs	46 lbs



Photo above reveals consolidated concrete barriers created within the Fox Buck

The 1" x 1" notches create a dual barrier against drafts and moisture penetration. When installed properly, the concrete barrier protection is continuous around the entire opening. These barriers also anchor the Fox Buck to the wall with enough strength to hold in most weather* conditions

* Contact Fox Blocks for high wind anchoring recommendations.



FOX BUCK INSTALLATION

INSTALLATION STEPS:

STEP 1

- a) Build wall as normal with opening 4" larger than rough opening.
- b) Ensure all opening rebar is properly placed and secured.
- c) Double check opening measurements.

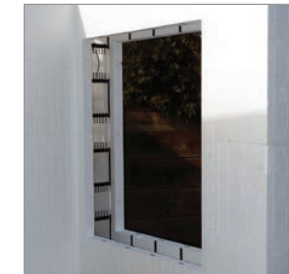

STEP 2

- a) Cut sides to length and notch each end 1" as in photo.
 - b) Place Fox Buck sides into place and hold with tape.
- Option: Spray foam can be used to completely seal buck to block

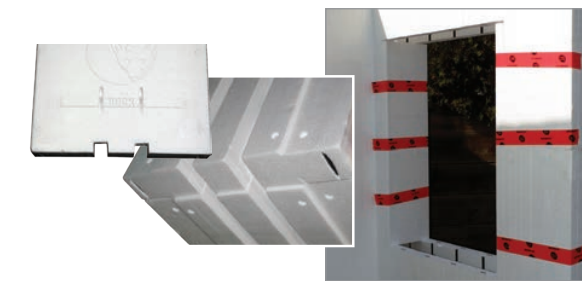

STEP 3

- a) Cut and place top and bottom Fox Bucks
- Option: Spray foam can be used to completely seal buck to block
- b) Penetrate all slots with a nail or screw to ensure entrapped air can escape during concrete placement.

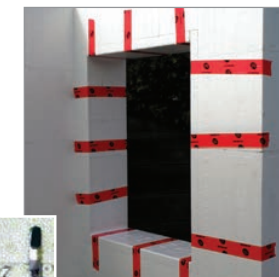

STEP 5

Brace inside opening to hold square during concrete placement.



STEP 4

Cut and remove all circles in sill. This will ensure proper concrete consolidation during concrete placement.

Notes:
It is preferred to have these circles cut out prior to placing the Fox Buck sill in place. This will eliminate any foam cutouts accidentally falling into wall cavity.

Holes can be cut square to allow maximum hole size for concrete placement.



STEP 6

When openings are close to a corner, strapping is required to hold corner in place during concrete placement.





Fox Blocks Products & Accessories

FOX BLOCKS ENERGY STICK

How do you improve an Insulated Concrete Form wall that already out-performs most wall systems in all climates? You move the concrete mass toward the living side of the wall. This unbalanced R-value will allow the mass to be closer to the living temperature of the conditioned space allowing for a more comfortable building.

The Fox Blocks design team had two goals: 1) Move the mass away from the harsh temperatures and 2) Increase R-value. Each Energy Stick is 8" wide, 32" tall, 2" thick and profiled to fit within all Fox Blocks. The Energy Stick is used to ensure an R-8 boost to the already high R-Value of Fox Blocks.

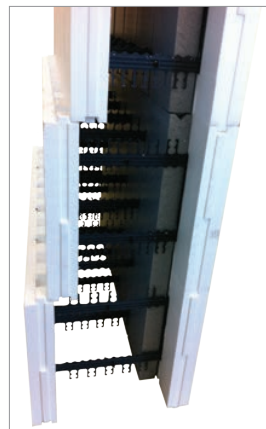
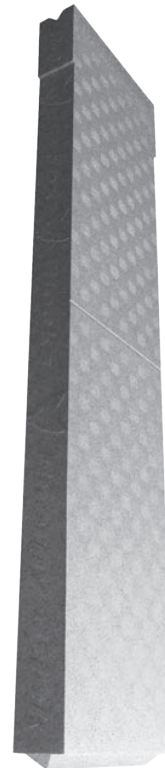

SIZING AND ACTUAL R-VALUE

- 6" Block + 1 Energy Stick (R-30+*) = 4" Concrete
- 8" Block + 1 Energy Stick (R-30+*) = 6" Concrete
- 10" Block + 1 Energy Stick (R-30+*) = 8" Concrete
- 10" Block + 2 Energy Sticks (R-39+*) = 6" Concrete
- 12" Block + 1 Energy Stick (R-30+*) = 10" Concrete
- 12" Block + 2 Energy Sticks (R-39+*) = 8" Concrete
- 12" Block + 3 Energy Sticks (R-48+*) = 6" Concrete

* This represents the overall average wall R-value. As an example in wood frame construction a wall with R-19 batt insulation will have an overall average wall R-value of less than R-16 due to thermal bridging.

USING THE ENERGY STICK:

- 1) INSTALLATION:**
Simply insert the patent pending Energy Sticks between the plastic ties and to the outside face of wall after every two rows of blocks have been placed.
- 2) CORNER BLOCKS:**
Fox Block corners are naturally thicker eliminating the need to insert Energy Sticks from the corner tie on. From the last straight tie to the corner tie you will need to wedge the Energy stick in place. A spot of expanding foam will also help to secure the Energy Stick from movement.
- 3) OPENINGS/STACKED SEAMS:**
Simply cut the Energy Stick to fit in locations that are narrower than 8". When larger than 8" use expanding foam to hold cut Energy Sticks.
- 4) RANGE OF USE:**
The Energy Stick will fit all Fox Blocks.
- 5) ESTIMATING:**
3 Energy Sticks for every block ordered.
One box = 36 Energy Sticks
One box of Energy Sticks will fill 12 blocks
- 6) MAN HOURS:**
Allow 4 minutes per box when inserting for the first time (= 950 square feet of wall per hour or .001 man hours per square foot)
- 7) BUNDLE SIZES:**
Each box of 36 Energy Sticks = approximately 24" x 24" x 33"



FOX BLOCKS ENERGY STICK FACTS

BASE

The bottom of each Energy Stick is shaped to insert into the top of the previous Energy Stick. The projection is 1/2" which is the same height as the projections on the block. This way, if the projection is left on the bottom of row one, the Energy stick will rest on the footing or slab.

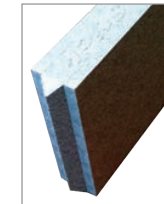

TOP

The top of each Energy Stick has a recess to accept the bottom of the next Energy Stick. This eliminates movement during concrete placement.

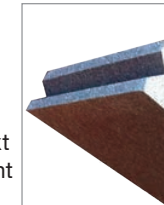

CONNECTION

The top of every Energy Stick is designed to fit snug between the ties. The lower 18" is designed to slide into the block loosely to increase production, and guide itself to connect to the top of the previous Energy Stick.



SHOULDER

Every Energy Stick has a specially designed shoulder as a stop to ensure every Energy Stick locks into the proper location.



FOX 1440

The Energy Sticks have been designed to work well in the solid Fox Blocks line as well as the 1440 line.



R-VALUE

Each Energy Stick layer will add R-8 to the wall. You can insert the energy stick on one or two faces to achieve the R-value desired. As an example, you could add three Energy Stick layers into the 12" block giving as much as R- 45+ with 6" of concrete!



ADDED BONUS

Fastening point stays consistent with standard blocks. No need for long screws for any attachments!

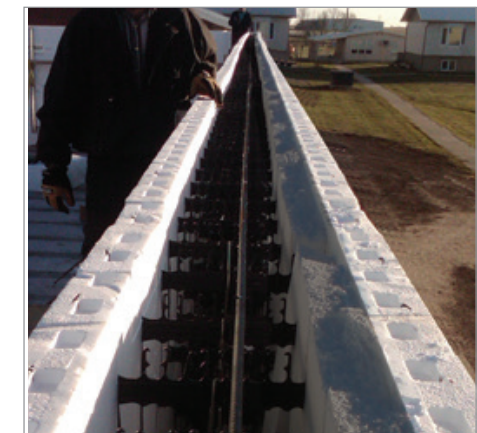

ENERGY STICKS IN USE *Patent Pending*
Energy Sticks have been field tested. The example above shows a wall that was 9 rows high which meant the top row used Energy Sticks that were cut in 1/2. Energy Sticks are marked with a cut line for jobs that have an odd number of rows.

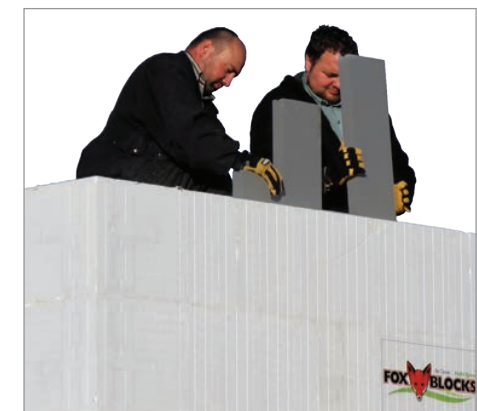



Fox Blocks Products & Accessories

xLERATOR® LEDGE REINFORCEMENT

From foundation to finish, Fox Blocks' patented family of products helps you get the job done more efficiently. Combining industry feedback with the creativity of Fox Blocks' product design team, we offer an impressive array of ICF product innovations that benefit the owner, the contractor, AND the design team.

FOX BLOCKS' xLERATOR – the only product of its kind in the industry and first one to meet ACI 318 guidelines – is a patented ICF ledge reinforcement system that offers unmatched versatile performance ideal for supporting brick and stone exterior finishes, as well as slabs, floors and other structural features.

The one-piece, 4-foot long, welded wire reinforcement piece simply drops into the pre-formed slots in Fox Blocks' ledge form.

There's never been a faster way to meet deadlines and building code requirements, all while significantly reducing labor costs and delays associated with pre-bent stirrups or in-field rebar reinforcement.



BENEFITS INCLUDE:

- **DROP & GO**
Fully engineered ledge system allows you to easily place the ledge form, drop in the xLerator reinforcement piece and fill with concrete.
- **ACI 318 COMPLIANT**
ONLY xLerator meets ACI 318 guidelines for ICF ledge reinforcement.
- **WEATHER RESISTANT**
Hot-dipped galvanized to protect from corrosion for lasting durability.
- **FULLY ENGINEERED**
Comes complete with full engineering details for multiple applications.
- **MAXIMUM STRENGTH**
Reinforcement in all 6 ledge corbels.
- **VERSATILE**
One size fits both 6" and 8" ledge forms.

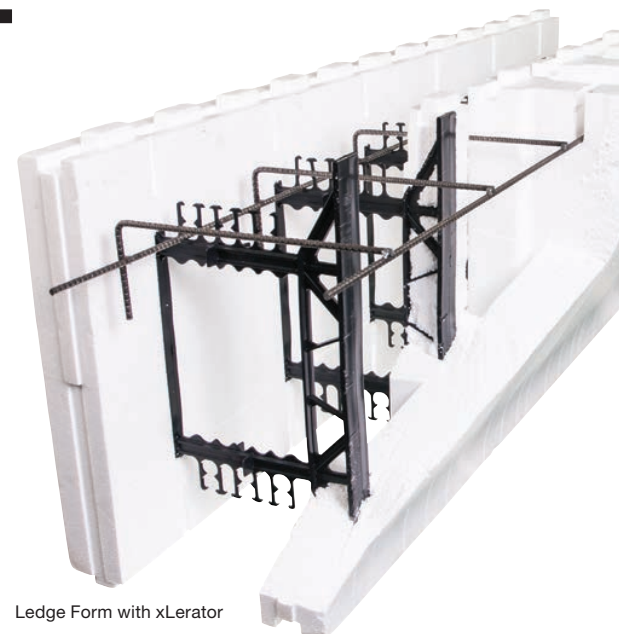

Ledge Form with xLerator

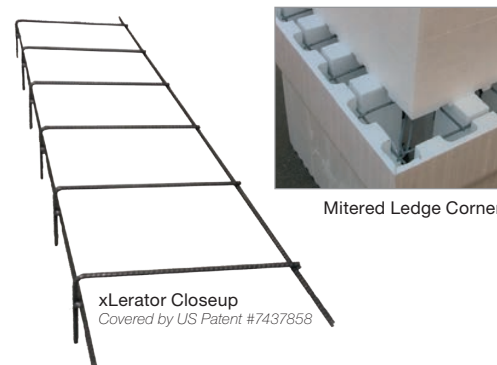

Mitered Ledge Corner

xLerator Closeup
Covered by US Patent #7437858

WHY HOT-DIPPED GALVANIZED?

Hot-dip galvanization is the process of taking steel and dipping it into molten zinc to serve as a protective coating. If rebar in a ledge form is NOT galvanized, it's subject to corrosion because it is placed close to the outside edge of the brick ledge, sits in a foam slot, and is not completely encased in concrete. This allows water to reach the rebar and causes it to rust. As the rebar rusts, it expands, causes concrete to crack, and undermines the stability of the ledge.

Since the xLerator is hot-dipped galvanized, it protects the reinforcement from rusting and maintains the integrity of the concrete meeting ACI 318 guidelines.

APPLICABLE ACI 318 GUIDELINES
Deformed Welded Wire Reinforcement (WWR)

- Reinforcement in every corbel
- WWR 60,000 PSI Yield Strength
- xLerator meets these guidelines



xLERATOR® ENGINEERING LOAD CAPACITY

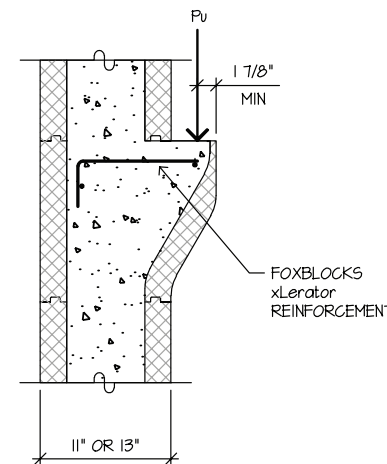

ULTIMATE LOAD CAPACITY, PU = 2000PLF	
Example Application	Calculated ultimate load tributary area X Load X Load Factor
Brick	35 Ft. X 40 PSF X 1.4 = 1960 PLF
Stone	17.5 Ft. X 80 PSF = 1960 PLF
Wood Floor Joists	22.5 Ft. tributary area or 45 Ft. clear span 22.5 Ft. X (20 PSF X 1.2 + 40 PSF X 1.6) = 1980 PLF
Precast Hollowcore Floor	14.5 Ft. tributary area or 29 Ft. clear span 14.5 Ft. X (60 PSF X 1.2 + 40 PSF X 1.6) = 1972 PLF

- Notes:
1. Load capacity is based on a concrete strength of 2500 PSI or greater and to KSI Fox Blocks' xLerator reinforcement meeting ASTM A496
 2. Load factors are based on ACI 318-11.
 3. Tributary floor span is the length of floor supported by the ledge form, which is commonly half of the clear span.
 4. Acceptable masonry heights and floor spans shown in the table are based on the structural capacity of the ledge only and may be limited by other factors. Consult a design professional for acceptable heights or unsupported masonry and floor spans.

tieKEY® ICF MASONRY ANCHOR

Designed by Fox Blocks Wall Systems, the tieKey anchor is the only patented ICF Masonry Anchor in the market. The cast-in-place, adjustable masonry tie anchor embeds into the concrete wall formed by the Fox Blocks ICF. This award winning product was designed to provide the strength and security required when installing brick or stone veneer finishes.



Wire Tie Not Included

tieKey Closeup
Covered by US Patent #8347531

SEE HOW THE TIEKEY HAS BEEN PUT TO THE TEST:

- Third party tested for tension and compression strength.
- Simplifies the installation of brick or stone exterior finishes.
- Adjustable wire tie accommodates construction tolerances and allows for larger differential movement for the brick finish.
- Provides a strong resistance to negative and positive lateral forces.
- Available in two materials: hot-dipped galvanized steel or stainless steel.
- Recipient of the World of Concrete's Most Innovative Products Award.



tieKey In Use





How-To Section

FOX BLOCKS STEEL SHELF ANGLE ATTACHMENT

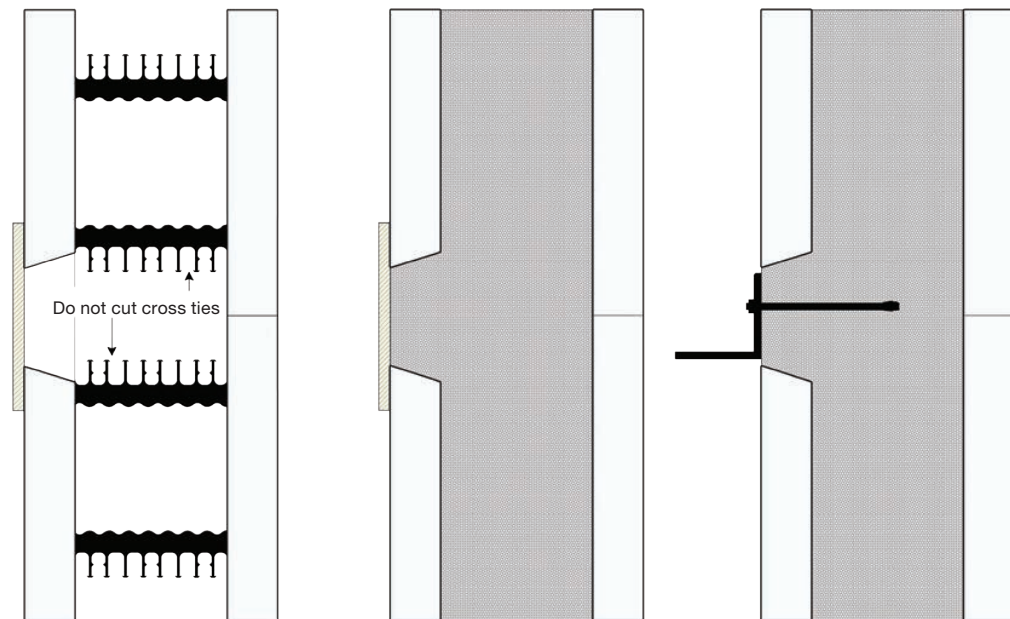

Rip cut blocks on table saw.

Use form plywood to cover. Common 2 1/2" deck screws work well into the 1 1/2" wide 8" o/c ties.

Post concrete remove form plywood and you have termite protection or solid concrete to attach steel angle etc.

Each section marked 'FOX BLOCKS' consists of a 1.5" wide continuous fastening zone buried 5/8" beneath the EPS foam.

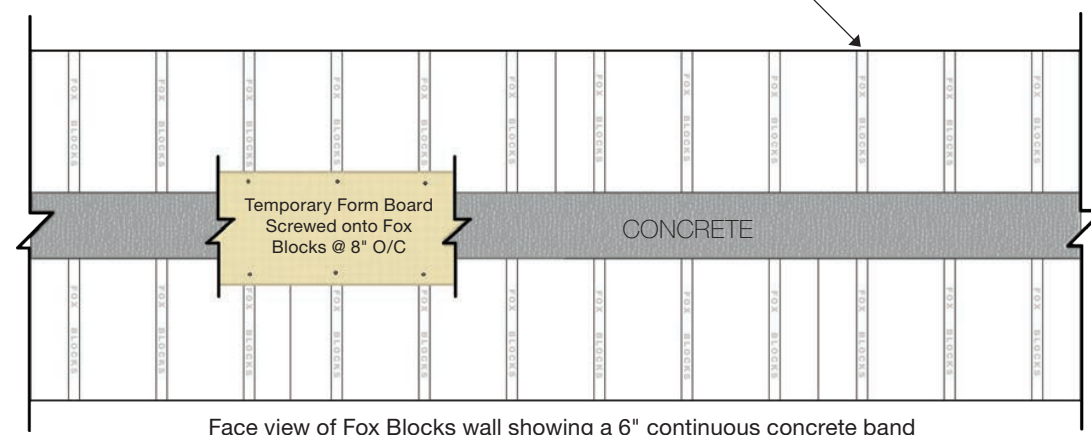

Face view of Fox Blocks wall showing a 6" continuous concrete band

The Fox Blocks design has consistent measurements due to the cross tie locations and full height ties. This will help when laying out a job that requires continuous bands of concrete.

FOX BLOCKS RIM JOIST ATTACHMENT

There are several ways to attach a floor diaphragm to a Fox Block wall. The most common has been to simply use common anchor bolts. See bottom for several other options

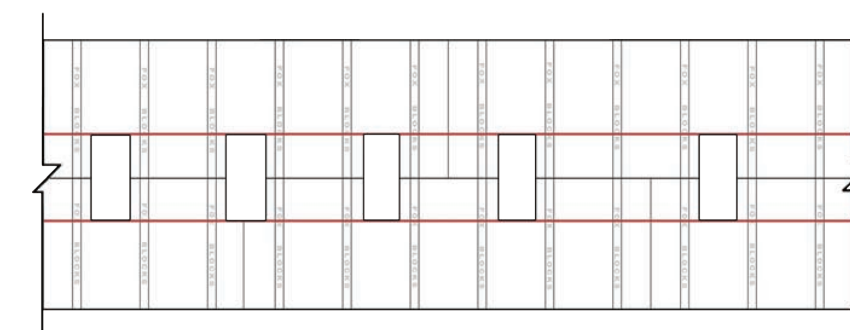

STEPS FOR RIM JOIST ATTACHMENT:

- 1) Build wall to within one row above rim joist location
- 2) Mark out top and bottom of rim joist location
- 3) Mark out o/c locations for anchor bolts
- 4) Cut out 4" x height of rim joist. Angle top cut up into block to allow air to escape during concrete placement.

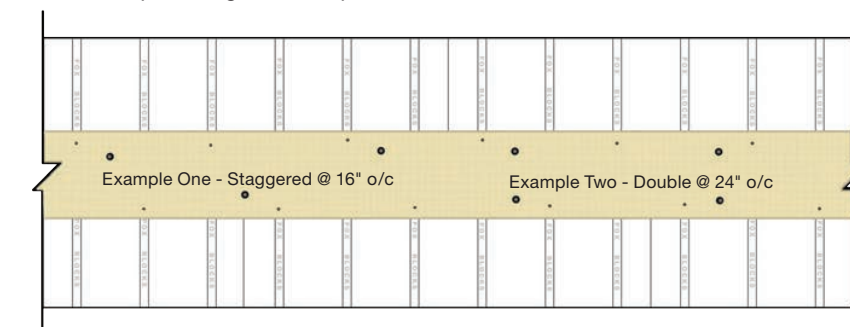

- 5) Place rim joist and attach to Fox Block ties with 3" deck screws
- 6) Mark out anchor bolt locations and drill holes
- 7) Reach inside the Fox Block wall and insert the anchor bolt through the hole you drilled
- 8) Place washer and nut onto anchor bolt. You are now ready for concrete.

OTHER OPTIONS INCLUDE:

- A) Simpson StrongTie ICF Ledger Connector: <http://www.strongtie.com/products/connectors/icfv1.asp>
- B) Fox Block corbel ledge: <http://www.foxblocks.com/Resource-Center>

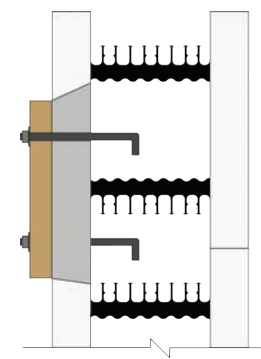

End view of completed Rim Joist attachment



How-To Section

FIELD CUT CORNERS

WHEN A MITERED CORNER IS NEEDED

- 1) Place a straight block on top of another block and rotate to the desired angle. Take care to place plastic ties in a position that will minimize the amount of cutting.
- 2) When you are satisfied with the positioning mark both block on the outside faces where they meet. Notice in the example the block was positioned so no plastic ties are cut. *See Note B.*
- 3) Cut both block and position in the wall. Take care to ensure the block has been cut so that it does not force the wall apart. It is better to be a bit short than too long. *See Note A.*
- 4) Once wall is built, stitch and brace the outside with plywood or dimensional lumber. At this point some spray foam can be used to fill in any gaps as long as you have it braced together to keep the expanding spray foam from pushing angle apart.

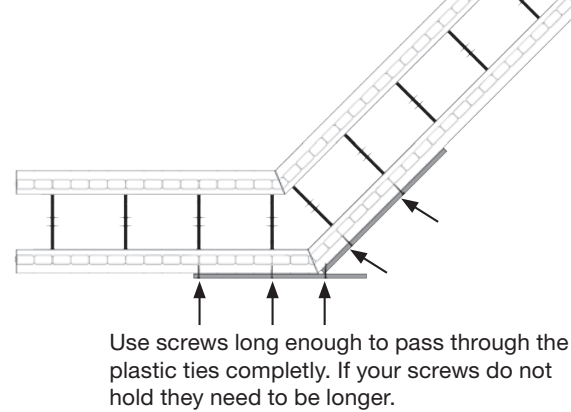
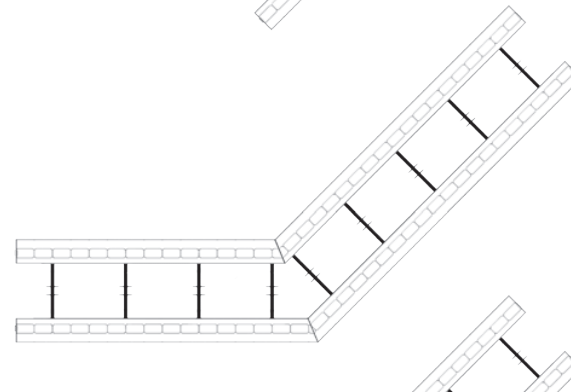
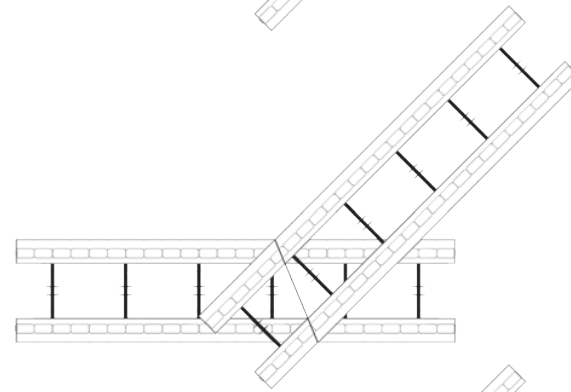
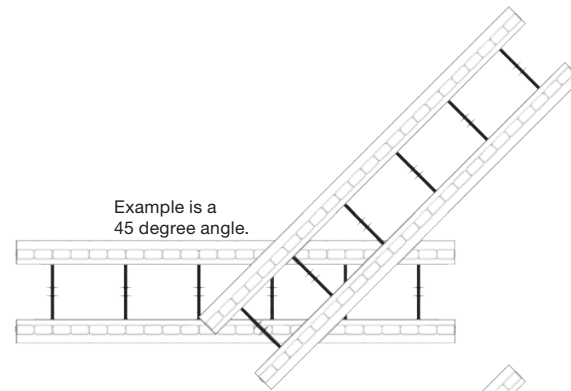

5) Place concrete

NOTE: Corner will have a very high load of concrete during placement. Please take the time to brace the corner properly.

Notes:

- A) It is better to be short than it is to be long when making cuts. If the cuts are short you can always use spray foam once the wall is completely built, leveled and plumbed.
- B) Plastic ties can be cut if needed as the corner will be braced with lumber anyway. We just try to not cut through the plastic because it takes more effort.
- C) When cutting remaining rows of block ensure the cut starts at the same location as the first row so that interlock will line up.
- D) Do not use spray foam until wall is completed prior to concrete.

FOX BLOCKS SHALLOW FROST/STEM WALLS

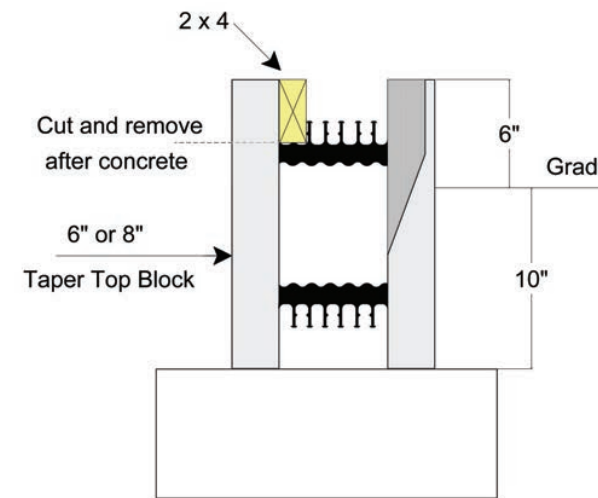

One row of Fox Blocks. Fox Blocks is designed to accept a 2 x 4 resting on top of the tie. Attach with screws through face of tie.

Footings and reinforcing to meet local building codes.

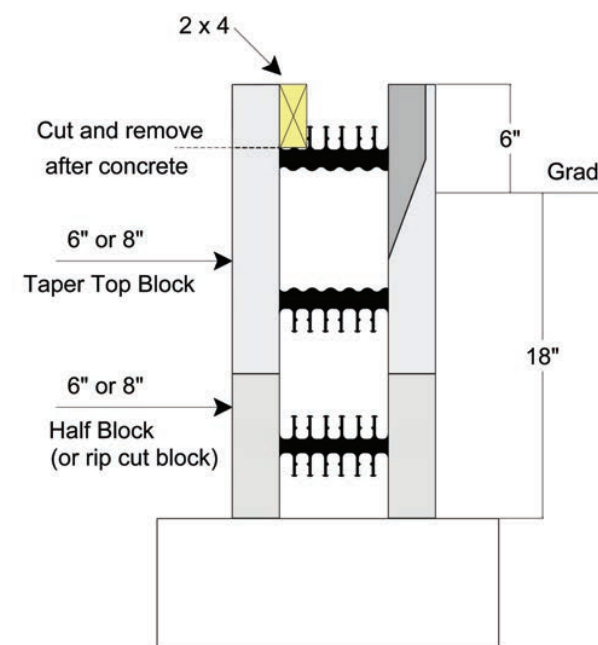

One and one half rows of Fox Blocks

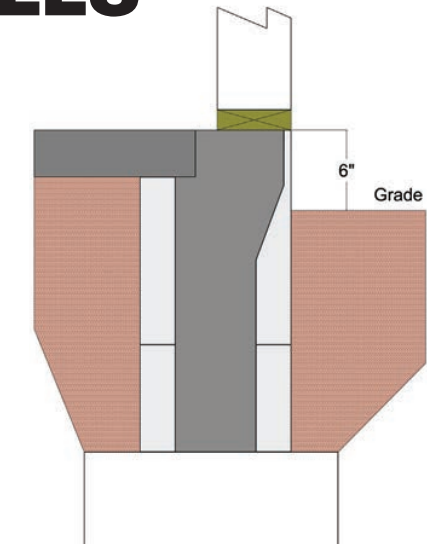

After concrete placement, cut block and remove 2 x 4 to create a shelf for slab to rest on.

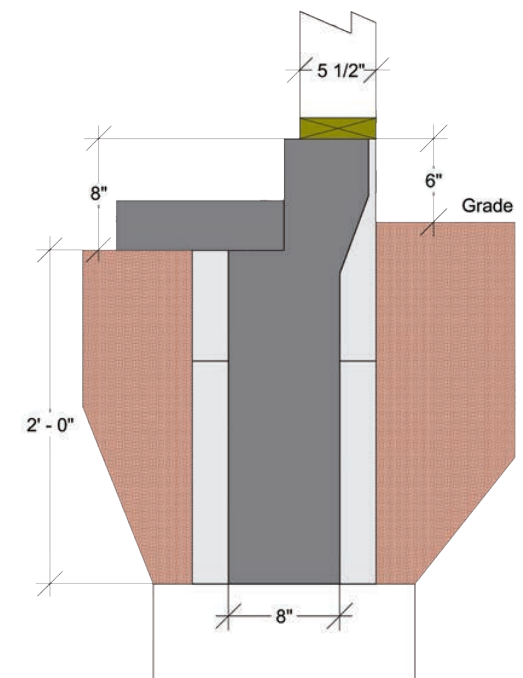

Using Curb Block allows you to lower slab to give a curb that does not require any finish. Taper is field cut into the top outside edge



How-To Section

ICF BRACING/SCAFFOLD

When building walls over three courses tall Fox Blocks recommends the use of ICF Bracing/Scaffolding.



The above photo shows two racks of 24 bracing sets for a total of 48 sets. At six foot on center this would be enough for 288 lineal feet of ICF wall.



Simply stake or screw the turnbuckle feet to the ground or floor



With the proper kits this type of scaffold can be used for walls up to 24' tall. Contact Fox Blocks for walls over 24' tall. It has become common to see walls 30' to over 60' tall.

FACTS

- 10' Brace Set = 75 Lbs
- 12' Brace Set = 88 Lbs
- 24 x 10' and rack = 1950 Lbs
- 24 x 12' and rack = 2250 Lbs
- Budget one brace every 6' of wall
- End user provides planks railing & screws

ICF BRACING/SCAFFOLD HAVE THREE MAIN PARTS:

- 1) STIFF BACK WHICH IS ATTACHED TO THE STUDS IN THE WALL**
Screw to ties in block which are 8" o/c. One screw per block row.
- 2) TURNBUCKLE WHICH ADJUSTS THE WALL.**
Threaded rod within the turnbuckles tilt wall in or out as you turn it.
- 3) PLANK SUPPORT ARM FOR SCAFFOLD.**
Will accept two 2 x 10's and toe kick.

* Guard rail posts are also provided for those taller jobs

WHY WE USE ICF BRACING/SCAFFOLD

Safe work site and straight walls

The use of a string line will give you straight walls. No one has an eye good enough to straighten walls longer than 20'.



10' or 12' Giraffe Scaffold AVAILABLE THROUGH FOX BLOCKS Racks of 24 sets



Estimating Fox Blocks

FOX BLOCKS ESTIMATOR PRO 4

TAB 1: WALL DATA

Fill in the basics, height, length width and whatever else your job will need.

TAB 2: OPENINGS

As an option you can input openings one at a time or in groups. The data can then be transferred to the wall data page.

TAB 3: FOX PARTS

Will give you the Fox Blocks parts needed for this page.

TAB 4: WORKSHEET DATA

A printable page showing all numbers you have entered, all product required as well as additional information like bracing requirements.

TAB 5: WORKBOOK SUMMARY

This is the pricing page which allows you to input and save your price lists and gives totals for entire project.

TAB 6: REBAR CALCULATOR

Allows you to calculate total footage of rebar for your job including footings and slabs.

TAB 7: CONCRETE CALCULATOR

Allows you to calculate total concrete needed for your job including footings, piles and slabs.

TAB 8: 1440 TILT CALCULATOR

Calculates parts needed for tilt up jobs using the Fox Blocks 1440 product.

TAB 9: MAN HOURS

Import worksheet numbers and easily calculate cost of job.

FILE MENU

Save your estimates as .fox files and choose from a variety of printouts

JOB NAME & INFORMATION

Fill out the job name and client information. There is no limit to the number of levels in your project.

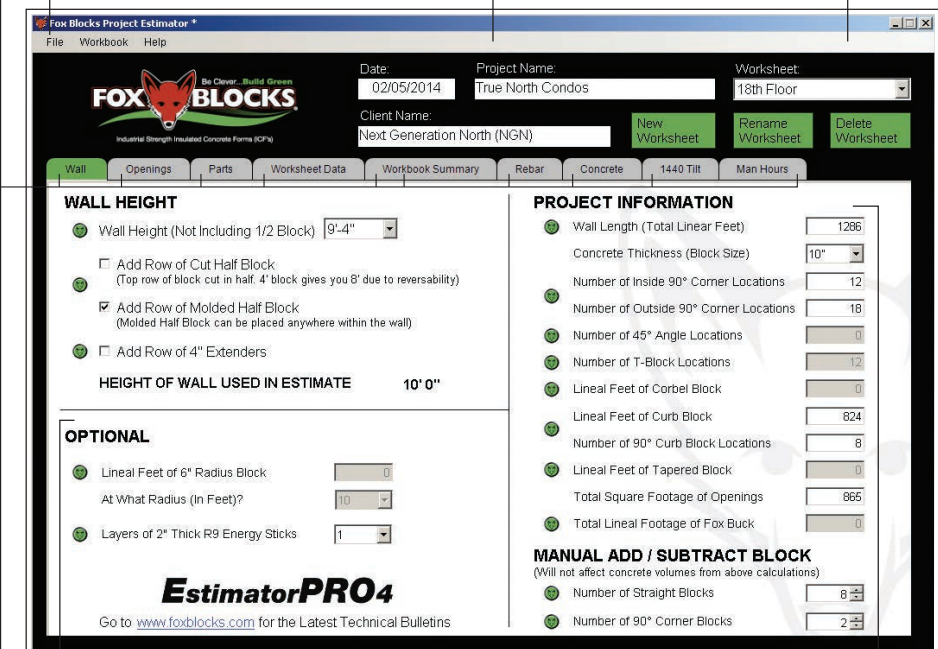

OPTIONAL RADIUS BLOCK AND R9 ENERGY STICKS



Go to <http://www.foxblocks.com/project-estimator/> to download the full Estimator PRO 4 for Windows or MAC.



Fox Blocks Project Estimator Mobile is easy to use and available anywhere. Use for your project take offs and estimates. Project Estimator Mobile will estimate ICF quantities including: specialty blocks, opening material, ancillary products, lineal feet of rebar, volume of concrete, and man hours.

Created by industry professionals with decades of intensive, technical experience in the ICF construction industry, the Project Estimator Mobile gives you the same power as the pro version. With Project Estimator Mobile, you are able to save your files on the go and access them later on your laptop or on any device where you've installed the app.



Estimating Fox Blocks

SAMPLE CROSS SECTIONS

Fox Blocks are designed to make walls. Take the time to understand your on site height requirements to ensure accurate material takeoffs.

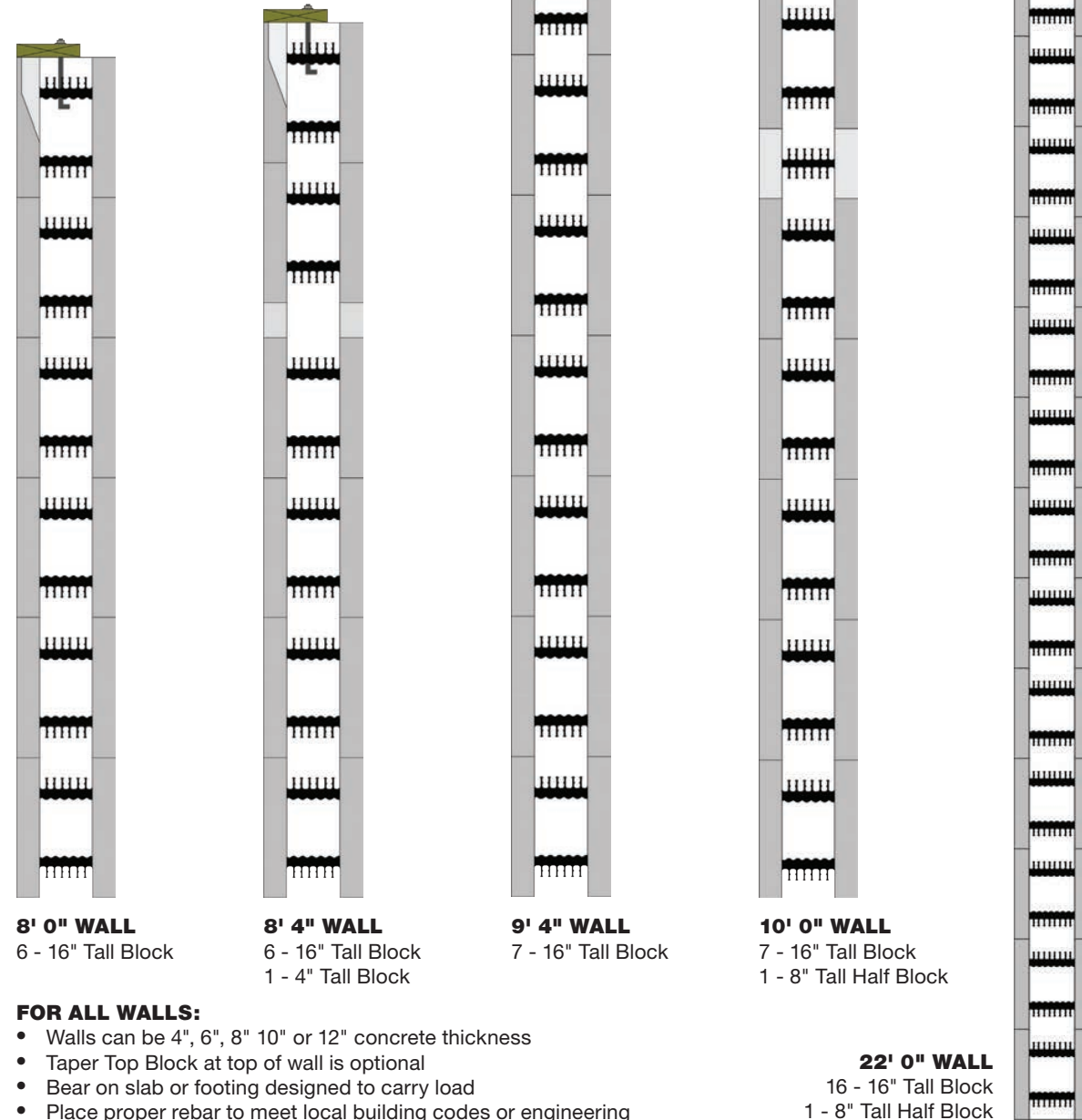

FOR ALL WALLS:

- Walls can be 4", 6", 8", 10" or 12" concrete thickness
- Taper Top Block at top of wall is optional
- Bear on slab or footing designed to carry load
- Place proper rebar to meet local building codes or engineering

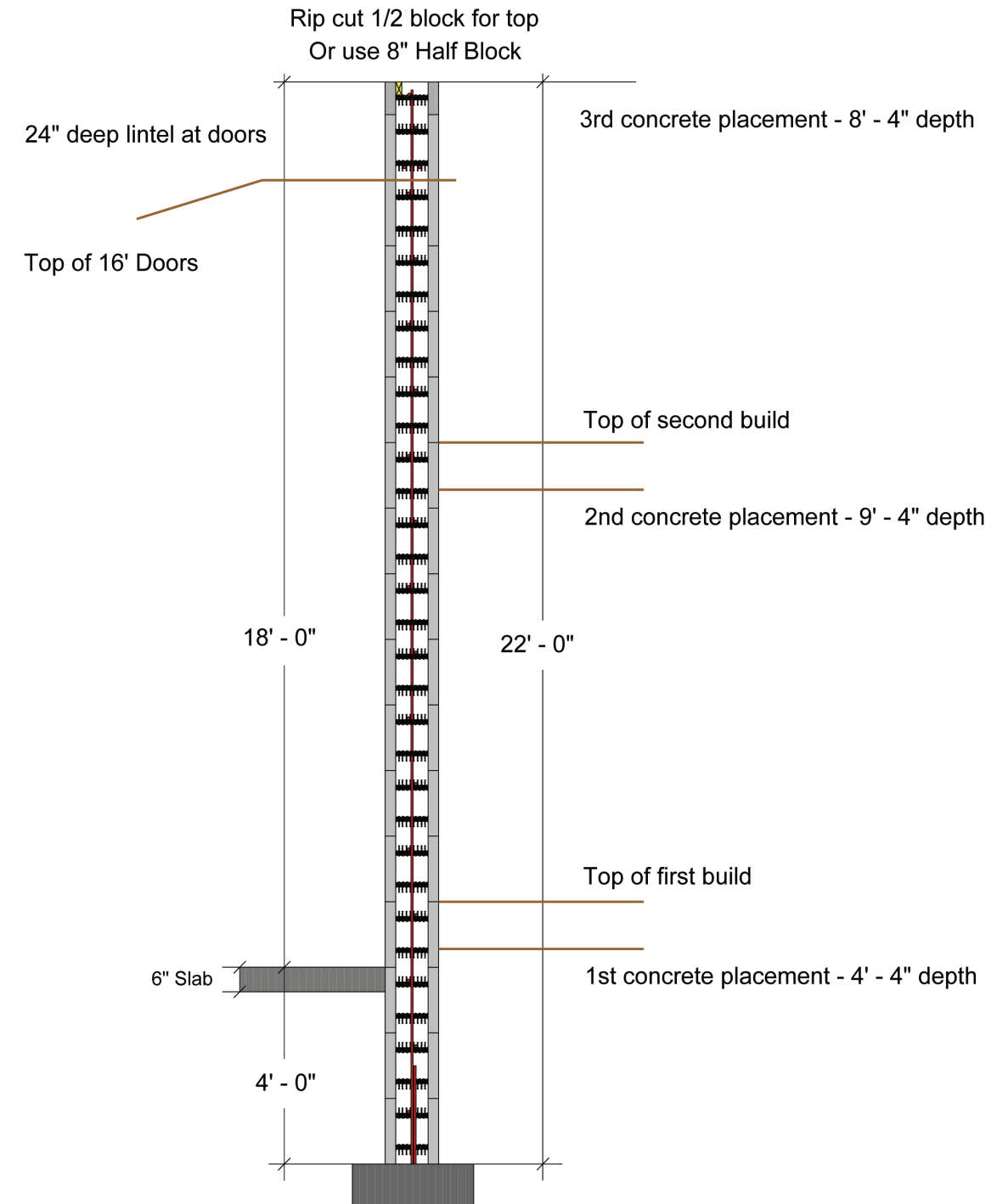

22'-0" TALL SAMPLE SHOP WALL

When planning any wall you want full understanding of the job for accurate takeoffs and low man hour rates. The above job required a 4'-0" stem / frost wall and 16'-0" tall door openings. The contractor used the same cross section to decide the concrete lift heights. The concrete lift heights decides the vertical rebar lengths.



Estimating Fox Blocks

BASIC ESTIMATING

Fox Blocks offers three methods to calculate the block for your project:

- 1) Use the basic math below to quickly calculate your estimate.
- 2) You can go to the website www.foxblocks.com and use the Project Estimator.
- 3) You can go to the website www.foxblocks.com and download the stand alone Project Estimator Pro which includes most aspects of an ICF build.

ESTIMATING BASIC QUANTITIES OF FOX BLOCK FOR YOUR PROJECT USING BASIC MATH:

STEP ONE - COLLECT DATA:

Size of block needed (4", 6", 8" or 12") = **A** _____
 Add up the total linear footage of the job = **B** _____
 The number of courses (rows) required:
 (Wall height in inches / 16" or use chart) = **C** _____
 Number of 90° turns for job = **D** _____
 Inside 90° turns = **E** _____ Outside 90° turns = **F** _____
 Number of turns for job other than 90° = **G** _____
 Number of T-Block locations = **H** _____
 Square footage of openings = **I** _____

STEP TWO - CALCULATE BLOCK REQUIREMENTS:

90° block needed: **D** x **C** (Total number of 90° turns times the number of rows high)
 45° block needed: **G** x **C** (Total number of 45° turns times the number of rows high)
 T Block needed: **H** x **C** (Total number of T Block locations times the number of rows high)
 Straight Block needed: (Use chart and calculations below)

Fox 90° Corner Size Chart		
Block Size	Length in feet	
	Inside	Outside
4"	① = 3.5	② = 5.0
6"	① = 3.5	② = 5.3
8"	① = 3.6	② = 5.6
10"	① = 3.6	② = 5.6
12"	① = 3.7	② = 6.3

Fox 45° Corner Size Chart		
Block Size	Length in feet	
	Inside	Outside
4"	③ = 3.5	③ = 3.5
6"	③ = 3.5	③ = 3.5
8"	③ = 3.5	③ = 3.5
10"	③ = 0.0	③ = 0.0
12"	③ = 0.0	③ = 0.0

T-Block Size Chart		
Block Size	Length in feet	
	Inside	Outside
4"	④ = 0.0	④ = 0.0
6"	④ = 3.5	④ = 3.5
8"	④ = 3.5	④ = 3.5
10"	④ = 0.0	④ = 0.0
12"	④ = 0.0	④ = 0.0

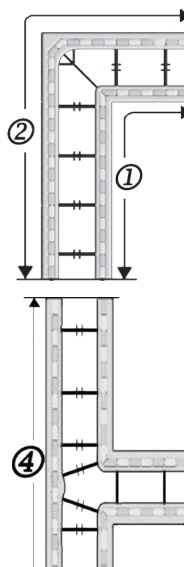

$(E \times ①) + (F \times ②) + (G \times ③) + (H \times ④) = \mathbf{J}$ _____ (Linear feet of wall taken up by corners and T Block)
 $B - \mathbf{J} = \mathbf{K}$ _____ (Total linear feet of wall taken up by straight block)
 $I / 5.33 = \mathbf{L}$ _____ (Number of block taken up by openings. 5.33 is sq. ft. per block)
 $(\mathbf{K} \times \mathbf{C}) - \mathbf{L} =$ Total Straight block needed for job not including waste factor. (Add 3% for waste)

See next page for more calculations.

Wall Height options:					
ACTUAL	DECIMAL	INCHES	ROWS	4" ext	Half Block
2'-8"	2.67	32	2	0	0
3'-4"	3.00	36	2	1	0
4'-0"	4.00	48	3	0	0
4'-4"	4.33	52	3	1	0
5'-4"	5.33	64	4	0	0
5'-8"	5.67	68	4	1	0
6'-8"	6.67	80	5	0	0
7'-0"	7.00	84	5	1	0
7'-4"	6.67	80	5	0	1
8'-0"	8.00	96	6	0	0
8'-4"	8.33	100	6	1	0
8'-8"	8.00	96	6	0	1
9'-4"	9.333	112	7	0	0
9'-8"	9.667	116	7	1	0
10'-0"	9.333	112	7	0	1
10'-4"	9.667	116	7	1	1
10'-8"	10.667	128	8	0	0
11'-0"	11.000	132	8	1	0
11'-4"	10.667	128	8	0	1
11'-8"	11.000	132	8	1	1
12'-0"	12.000	144	9	0	0
12'-4"	12.333	148	9	1	0
12'-8"	12.000	144	9	0	1
13'-0"	12.333	148	9	1	1
13'-4"	13.333	160	10	0	0
13'-8"	13.667	164	10	1	0
14'-0"	13.333	160	10	0	1
14'-4"	13.667	164	10	1	1
14'-8"	14.667	176	11	0	0

STEP THREE - OTHER TYPES OF BLOCK:

Taper Block needed (only available in 6" & 8"):

Linear feet of taper block need / 4 (4 = length of one corbel block)
Remove this number from the straight block count

Corbel Block needed (only available in 6" & 8"):

Linear feet of corbel block need / 4 (4 = length of one corbel block)
Remove this number from the straight block count

Radius block needed (only available in 6"):

Linear feet of radius block need / 1.33 (1.33 = length of one corbel block)
Remove one straight block for every three radius block needed

Curb Block needed (only available in 8" at this time):

Straights: (Total linear footage of wall - total linear footage taken up by 90° corners)/4 = number of straight curb blocks
 Remove this number from the straight block count
 Corners: Number of 90° turns = Number of 90° corner blocks
 Remove this number from the 90° corner block count

1/2 block needed (only available in straight and 90° corner blocks):

Same formulas as straight and 90° corner blocks.

Energy Sticks needed (will fit all block):

Total number of block for job x 3.

STEP FOUR - CALCULATE CONCRETE:

Fox blocks volume is exactly 4", 6", 8", 10" or 12" so calculate as you would other regular concrete formwork.

The following chart will give volumes per block:

Block Type	Concrete Volumes										
	Cubic Yards					Cubic Meters					
	Size					Size					
	4"	6"	8"	10"	12"		4"	6"	8"	10"	12"
Straight	0.066	0.099	0.132	0.165	0.198	Straight	0.05	0.076	0.101	0.126	0.151
90 corner	0.07	0.105	0.145	0.181	0.212	90 corner	0.054	0.08	0.111	0.138	0.162
45 corner	0.066	0.082	0.117	NA	NA	45 corner	0.05	0.063	0.089	NA	NA
Corbel Block	NA	0.129	0.162	NA	NA	Corbel Block	NA	0.099	0.124	NA	NA
Taper Block	NA	0.111	0.144	NA	NA	Taper Block	NA	0.085	0.11	NA	NA
T Block short	NA	0.105	0.141	NA	NA	T Block short	NA	0.08	0.108	NA	NA
T Block long	NA	0.121	0.152	NA	NA	T Block long	NA	0.093	0.116	NA	NA
Radius Block	NA	0.033	NA	NA	NA	Radius Block	NA	0.025	NA	NA	NA

STEP FIVE - MISC:

Fox Blocks HV Clips: One box for every 150 block ordered (One box = 250 Fox Block HV Clips)

Bracing: Linear feet of wall / 6'

Fox Buck: Lineal footage of openings / 4' and round up-

Rebar: (Number of rows needed x Linear feet of wall) + (Linear feet of wall / spacing needed)
Add 10% to horizontal rebar total for lap splices.



Estimating Fox Blocks

MAN HOUR RATES

- To budget a job properly for efficiency in crew size
- To budget a job properly to land job
- To be profitable

Man Hour Rates (MHR) have been around for decades. Most contractors document their production rates without realizing that time / square footage built will give them a man hour rate as you would find in most cost estimating programs such as RS Means. For most Insulated Concrete Forms (ICF) this has become a common practice. Over 20 years of history have established accurate numbers to budget future jobs with.

	MHR	JOB TYPE	NOTES:
1	.055 or less	Very efficient crew building a simple job with less than six corners, less than four openings and few or no embeds.	<p>Size of job is not as big a factor as you would think. The only time the size of job is really a factor is when the job is so large that the crew can gain speed while building which lowers the MHR. This will usually be on jobs over 20,000 square feet using the same crew throughout.</p> <p>WAYS TO LOWER YOUR MHR:</p> <ol style="list-style-type: none"> 1. Pre-Plan Job 2. Proper Size Crew for Job 3. Stage Materials Close to Job 4. Use Proper Scaffold/Bracing 5. Pre-Build Opening Bucks 6. Proper Rebar Placement 7. Fox Training for Crew
2	.06 .065 .07	Average job with less than eight corners, less than eight openings and less than eight embeds.	
3	.075 .08 .085	Most common MHR for new crews on moderate or large jobs. This will cover complex residential jobs with 12 or less corners. This MHR area will also work with large commercial jobs with basic 16" o/c rebar and few openings.	
4	.085 .095 .10 .105	Very complex residential with 12 or more corners and many openings and embeds. Also includes commercial jobs with many openings and embeds or more than 3 levels in height.	
5	.11 and over	ICF jobs with at least three of the following: More than 8 short corners (30" or less), high seismic rebar design, more than 20 openings, many embeds, extreme weather, using the wrong scaffold for wall height, over 3 levels in height.	

Square foot of Job (SFJ) = Length * Height (of Fox walls being built)

SFJ * MHR = MAN HOURS TO BUILD JOB

Example: Job has 180 Lineal feet (LF) of wall that is 12' tall. 180 * 12 = **2160** square feet (SF)
Job has 6 corners with 6 openings and basic 16" o/c rebar design. Crew has a bit of experience and ICF scaffold is used. We recommend aiming for a .075 MHR but use **.085** MHR as a budget number. With experience you will become more efficient, landing more work with more profit.
2160 * .085 = 183.6 Total Man Hours (TMH) for job
183.6 TMH / 6 man crew = 30.6 Total Crew Hours (TCH)

These numbers are estimates only. Many factors will effect the outcome of a job which needs to be taken into account. Please document all work and reflect back to your own crews history when completing budgets for upcoming work. We would like to thank contractors for sharing past history allowing us to build accuracy into this document.

Appendix

TECHNICAL PERFORMANCE DATA

Fox Block ICF Wall System

CONCRETE WALL CONSTRUCTION (4", 6", 8", 10" & 12" Reinforced Structural Concrete Core)

Design criteria for the structural concrete wall system	ACI 318 design standards for straight wall concrete construction
Recommended concrete consolidation	Reference the Fox Block Installation Manual, ACI 309
Fox Blocks Installation Manual	Second Edition (2012)
Prescriptive Design of Exterior Concrete Walls	PCA 100-2012, IRC R404.1, R611, ACI 332
Average weight of the reinforced structural concrete	150 lbs. / cu. ft. (including steel reinforcement)
Thermal Mass (form & 4" reinforced concrete core)	50 lbs. / sq. ft.
Thermal Mass (form & 6" reinforced concrete core)	75 lbs. / sq. ft.
Thermal Mass (form & 8" reinforced concrete core)	100 lbs. / sq. ft.
Thermal Mass (form & 10" reinforced concrete core)	125 lbs. / sq. ft.
Thermal Mass (form & 12" reinforced concrete core)	150 lbs. / sq. ft.
Recommended concrete core compressive strength	Minimum 3000 psi for the walls (minimum 2500 psi for footings)
Recommended concrete core slump flow for pump mix design	4" ICF - 6" to 7"; 6" ICF - 5.5" to 6.5"; 8", 10" or 12" ICF - 5" to 6"
Recommended aggregate size for the concrete mix design	4" ICF - 3/8" max.; 6" ICF 3/8" to 1/2" max; 8", 10" & 12" ICF - 1/2" to 3/4" max.

PRODUCT PERFORMANCE & THIRD PARTY TESTING

Expanded Polystyrene (EPS) Testing:

EPS Foam Resin	Modified low pentane, B/C bead size (resin is self-extinguishing)																
EPS Average Manufacturing Density / Type	1.5 lbs. / cu. ft. (Type II, Rigid Cellular EPS Foam Plastic)																
ASTM C578, EPS Thermal Insulation Properties	<p>Fire Safety & Testing:</p> <p>Surface Burning Characteristics of Foam Plastics, ASTM E84 & ANSI / UL 723</p> <table border="1"> <tr> <td>Flame spread from the EPS Foam</td> <td>less than 25</td> </tr> <tr> <td>Smoke Development of the EPS Foam</td> <td>less than 450</td> </tr> </table> <p>Surface Burning Characteristics of Foam Plastics, CAN / ULC S102</p> <p>Fire Burning Characteristics of Plastic Ties</p> <table border="1"> <tr> <td>ASTM D1929, Flash Ignition Temp</td> <td>400 (C) 752 (F)</td> </tr> <tr> <td>ASTM D1929, Spontaneous Ignition Temp</td> <td>380 (C) 716 (F)</td> </tr> <tr> <td>ASTM D635, Burn Rate</td> <td>Meets Class CC1</td> </tr> </table> <p>Fire Resistance Rating, ASTM E119 (equivalent Standard Test Methods)</p> <table border="1"> <tr> <td>4" Concrete Core</td> <td>2 hrs.</td> </tr> <tr> <td>6" Concrete Core</td> <td>4 hrs.</td> </tr> <tr> <td>8", 10" or 12" Concrete Core</td> <td>4 hrs.</td> </tr> </table> <p>Fire Endurance Test of Building Construction Materials, CAN / ULC S101</p> <p>Room Fire Test, UL 1715 (with 1/2" gypsum board)</p> <p><i>MSDS sheets available at www.foxblocks.com</i></p>	Flame spread from the EPS Foam	less than 25	Smoke Development of the EPS Foam	less than 450	ASTM D1929, Flash Ignition Temp	400 (C) 752 (F)	ASTM D1929, Spontaneous Ignition Temp	380 (C) 716 (F)	ASTM D635, Burn Rate	Meets Class CC1	4" Concrete Core	2 hrs.	6" Concrete Core	4 hrs.	8", 10" or 12" Concrete Core	4 hrs.
Flame spread from the EPS Foam		less than 25															
Smoke Development of the EPS Foam	less than 450																
ASTM D1929, Flash Ignition Temp	400 (C) 752 (F)																
ASTM D1929, Spontaneous Ignition Temp	380 (C) 716 (F)																
ASTM D635, Burn Rate	Meets Class CC1																
4" Concrete Core	2 hrs.																
6" Concrete Core	4 hrs.																
8", 10" or 12" Concrete Core	4 hrs.																
CAN / ULC S701, EPS Thermal Insulation Properties																	
Plastic Tie Strength Testing:																	
Fastener Withdrawal, ASTM D1761																	
Fastener Lateral (Shear), ASTM D1761																	
Tie Tensile and Shear, ASTM D638 and D732																	
Performance Testing:																	
Sound Transmission Class (STC), ASTM E90, STC 45-50+																	
Environmental, Safety & Energy Performance:																	
No HCFC's or CFC's emitted during the manufacturing process																	
No toxins or formaldehydes produced																	
Plastic ties are recycled and the EPS Foam forms are recyclable																	
Products & Energy Efficient Accessories:																	
Energy Stick	R-8 / Stick																
Energy Efficiency Data & Performance:																	
Thickness of the EPS	2.625" / wall panel (5.25" total EPS thickness)																
EPS Steady State R-Value (thermal resistance of the material)	R - 4.17 (@ 70 degrees Fahrenheit)																
CTL Group Thermal Resistance R-Value Calculation Report	R - 23+ / Block (calculated in accordance with ASHRAE 90.1)																
EPS K-Factor (thermal conductivity of the material)	K - 0.24 / inch (@ 70 degrees Fahrenheit)																
Air Leakage (infiltration rate) ASTM E283	0.002 cfm / ft²																
ORNL Thermal Mass Calculator Dynamic R-Value Equivalent	Greater than R - 32																

Storm Safety:

Wind Capacity	Fox Blocks ICF Walls can be designed to meet code requirements
Seismic Zones	Fox Blocks ICF Walls can be designed to meet code requirements

BUILDING CODE REFERENCES

IRR-1010	Miami-Dade County Product Division NOA # 13-0124.01
CCMC - 13472-R	Florida Product Approval - FL7497-R3 City of New York - MEA 201-08-M City of Los Angeles - RR25689 State of Wisconsin - 201403-1
ASTM E2634	
CAN/ULC S717.1	





Appendix

FOX BLOCKS BY THE NUMBERS

	Item Number	Block Type	Total Width	Total Height	Outside dimensions		Inside dimensions		Concrete Volume yd	Concrete Volume M	Bundle Quantity	Actual Bundle Size			Weight	
					Length	Surface area	Length	Surface area				Length	Width	Height	Bundle	Piece
4	FOX-S400	Straight Block	9.25	16	48	5.33	48	5.33	0.066	0.05	12	38	49	49	84	7
	FOX-S400HB	Straight 1/2 Block	9.25	8	48	2.67	48	2.67	0.033	0.025	24	38	49	49	84	7
	FOX-EC490	90° Corner Block (38 x 22)	9.25	16	60	6.67	41.5	4.61	0.07	0.0535	12	46	47	49	95	8
	FOX-EC490HB	90° Corner 1/2 Block	9.25	8	60	3.34	41.5	2.31	0.348	0.027	24	46	47	49	95	8
	FOX-BUCK4	Fox Buck	9.25	2	48	3.08	n/a	n/a	n/a	n/a	12	48	9.25	27.25	29	2.65
	FOX-EC445	45° Corner Block (34 x 18)	9.25	16	52	5.78	44	3.57	0.066	0.05	9	40	50	49	58	6.4
6	FOX-S600	Straight Block	11.25	16	48	5.33	48	5.33	0.099	0.0757	12	45.5	49	49	90	7.5
	FOX-S600HB	Straight 1/2 Block	11.25	8	48	2.67	48	2.67	0.0494	0.0378	24	45.5	49	49	90	3.75
	FOX-EC690	90° Corner Block (48 x 24)	11.25	16	64	7.11	41.5	4.6	0.105	0.08	12	53	49	49	102	8.47
	FOX-EC690HB	90° Corner 1/2 Block	11.25	8	64	3.56	41.5	2.31	0.0543	0.0415	24	53	49	49	102	8.47
	FOX-C645	45° Corner Block (26 x 18)	11.25	16	44	4.89	34.875	3.85	0.082	0.063	9	40	49	49	58	6.4
	FOX-TB600	T-Block Short	11.25	16	44	4.89	4.375	n/a	0.105	0.08	6 (3+3)	40.25	43.25	49	56	9.4
		T-Block Long	11.25	16	44	4.89	12.375	n/a	0.121	0.0925					56	9.4
	FOX-BL600	Corbel Ledge	11.25	16	48	5.33	n/a	n/a	0.129	0.099	9	45.25	45.5	49	80	8.8
	FOX-TT600	Taper Top	11.25	16	48	5.33	n/a	n/a	0.111	0.085	12	45.25	49	49	56	7.3
	FOX-RB600_	Radius	11.25	16	16	1.77	n/a	n/a	0.033	0.025	27	39	49	49	68	2.5
	FOX-BUCK6	Fox Buck	11.25	2	48	3.75	n/a	n/a	n/a	n/a	12	48	11.5	27.25	33	2.75
FOX-Strip 6	Strips for corbel block	n/a	n/a	n/a	n/a	n/a	n/a	n/a	n/a	40	13	11	9	25	0.65	
8	FOX-S800	Straight Block	13.25	16	48	5.33	48	5.33	0.132	0.101	12	54.5	49	49	90	7.5
	FOX-S800HB	Straight 1/2 Block	13.25	8	48	2.67	48	2.67	0.065	0.05	24	54.5	49	49	90	7.5
	FOX-EC890	90° Corner Block (42 x 26)	13.25	16	68	7.56	41.5	4.6	0.153	0.117	6	41	44	49	60	9.83
	FOX-EC890HB	90° Corner 1/2 Block	13.25	8	68	3.78	41.5	2.3	0.076	0.058	12	41	44	49	60	9.83
	FOX-C845	45° Corner Block (28 x 20)	13.25	16	48	5.33	37	4.11	0.117	0.089	9	53	47	49	58	6.4
	FOX-TB800	T-Block Short	13.25	16	44	4.89	4.75	n/a	0.141	0.108	6 (3+3)	40.25	43.25	49	56	9.4
		T-Block Long	13.25	16	44	4.89	8.75	n/a	0.152	0.116					56	9.4
	FOX-BL800	Corbel Ledge	13.25	16	48	5.33	n/a	n/a	0.162	0.124	9	53.25	49.5	49	80	8.9
	FOX-TT800	Taper Top	13.25	16	48	5.33	n/a	n/a	0.144	0.11	12	54.5	49.25	49	87	7.3
	FOX-S800CB	Curb Block - Straight	13.25	16	48	5.33	n/a	n/a	0.132	0.101	12	54.5	49	49	91.2	7.6
	FOX-EC890CB	Curb Block - 90° Corner	13.25	16	68	7.56	41.5	4.6	0.145	0.111	6	41	44	49	60	9.92
	FOX-BUCK8	Fox Buck	13.25	2	48	4.42	n/a	n/a	n/a	n/a	12	48	13.5	27.25	38	3.2
	FOX-Strip 8	Strips for corbel block	n/a	n/a	n/a	n/a	n/a	n/a	n/a	n/a	40	13.5	11.5	9.5	28	0.7
	10	FOX-S1000	Straight Block	15.25	16	48	5.33	48	5.33	0.165	0.126	9	46	49	49	74
FOX-S1000HB		Straight 1/2 Block	15.25	8	48	2.67	48	2.67	0.0823	0.063	18	46	49	49	74	7.86
FOX-EC1090		90° Corner Block (42 x 28)	15.25	16	68	7.56	41.5	4.6	0.181	0.138	6	41	44	49	68	10.5
FOX-EC1090HB		90° Corner 1/2 Block	15.25	8	68	3.78	41.5	2.3	0.092	0.07	12	41	44	49	68	10.5
FOX-BUCK10		Fox Buck	15.25	2	48	5.08	n/a	n/a	n/a	n/a	12	48	15.5	27.25	42	3.4
12	FOX-S1200	Straight Block	17.25	16	48	5.33	48	5.33	0.198	0.151	9	54	49	49	74	8.22
	FOX-S1200HB	Straight 1/2 Block	17.25	8	48	2.67	48	2.67	0.099	0.076	18	54	49	49	74	4.12
	FOX-EC1290	90° Corner Block (46 x 30)	17.25	16	76	8.42	41.5	4.6	0.212	0.162	6	46.5	49.25	49	68	11.17
	FOX-EC1290HB	90° Corner 1/2 Block	17.25	8	76	4.21	20.75	2.3	0.106	0.081	12	46.5	49.25	49	68	5.75
	FOX-BUCK12	Fox Buck	17.25	2	48	5.75	n/a	n/a	n/a	n/a	12	48	17.25	27.25	46	3.7
All	FOX-HV Clip	HV Clips	8	4	n/a	n/a	n/a	n/a	n/a	n/a	250	11	11	7	7	0.028
	FOX-tieKEY	tieKey	1.25	2.75	6	n/a	n/a	n/a	n/a	n/a	200	9.5	8.5	6.75	29	0.15
	FOX-xLERATOR	xLerator	48	10.31	n/a	n/a	n/a	n/a	n/a	n/a	9	52	13.5	6.5	22	2.45
	FOX-Extr	4" High Block Extender	2.625	4	48	1.33	n/a	n/a	0.049	0.0378	20	49	17	14	13	0.65
	FOX-Estick	R8 Energy Stick	2	32	8	1.78	n/a	n/a	n/a	n/a	20	49	17	14	13	0.65

Notes



FLOWERS



Industrial Strength Insulated Concrete Forms (ICF)



FLOWERS 184 Seymour Drive Industrial Park PO Box 900 GRAND CAYMAN KY1 – 9006 Cayman Islands
Phone: 345 623 0000 Overseas Toll Free: 1 727 495 0107 Email: customerservice@flowersgroup.com

www.flowersgroup.com

Like us on Facebook

